

TRANS



LRD-509 series

Line Voltage SmartDIM Occupancy Sensor

INSTALLATION INSTRUCTIONS

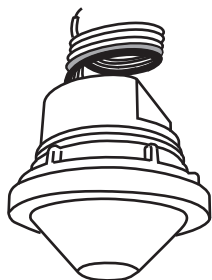

w/Lens A/B/C

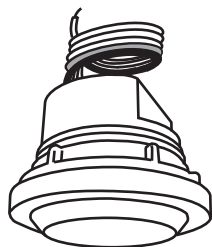

w/Lens D

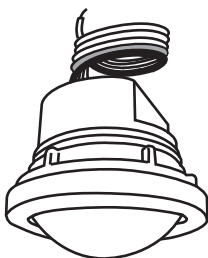

w/Lens F

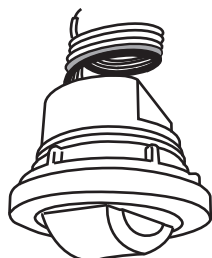

w/Lens G

⚠ WARNING & CAUTION

- Risk of Electric Shock - Disconnect power supply before servicing.
- Do NOT touch the square window of infrared sensor under the lens assembly.

Open Type Photoelectric Switches.

⚠ AVERTISSEMENT & PRUDENCE

- Risque de choc électrique - Débranchez l'alimentation avant l'entretien.
- Ne PAS toucher la fenêtre carrée de capteur infrarouge sous l'ensemble de l'objectif.

Ouvrir Type commutateurs optoélectroniques.

OVERVIEW

The LRD-509 series member of the TRANS family is a two-way IR remote programmable line voltage switching occupancy sensor with 0-10V output for dimmable ballast or LED driver control. The sensor is capable of providing top-notch energy efficient lighting control in multiple modes with fully programmable multi-level high/low dim or SmartDIM control. SmartDIM is a state-of-the-art automatic dimming control technology developed by IR-TEC, which is capable of maintaining the overall ambient light level within the preset range through a smooth, flawless continuous dimming control to the connected lighting.

The sensor will turn on the connected lighting to the high dim or **SmartDIM** level as programmed when it detects the presence of an occupant or vehicle, and automatically dim the light down to the low level or shut off as programmed after the area is vacated for a period of time. An exclusive two-way handheld remote programmer, SRP-280, is required to configure sensor setting, or download the existing settings of the installed sensors from the floor. In addition, an exclusive Hybrid Switching technology makes the LRD-509 series perfect sensor to control a group of LED lightings with exceptionally high inrush current (HIC) while switching on.

Like all sensors in the TRANS family, the LRD-509 series is available with various mounting options and interchangeable lenses. This provides a second-to-none design and complete installation flexibility. The sensor is designed to operate in the coldest of environments, down to $-40^{\circ}\text{C}/^{\circ}\text{F}$.

APPLICATION NOTES

1. The sensor is more sensitive to the movements "crossing" the detection zones than "toward" or "away" the sensor unit. To obtain better sensitivity, avoid placing the sensor in line with occupant path, if possible.
2. The closer the movement is to the sensor, the more sensitive the sensor is. The higher the sensor is installed, the larger movement is required to be detected.
3. Ensure to place the sensor at least at 1.5m (5 ft.) away from air supply ducts as rapid air flow may cause false activations.
4. The sensor cannot "see" the movements behind obstacles, such as furniture, shelf, glass or partition. As a general rule, each occupant should be able to clearly view the sensor unit.
5. For open office areas with partition which could block the sensor view to occupant movements, it is best to place the sensors over the intersection of multiple workstations. For large areas of open office or space, place multiple sensors so that there is overlap coverage with each adjacent sensor.

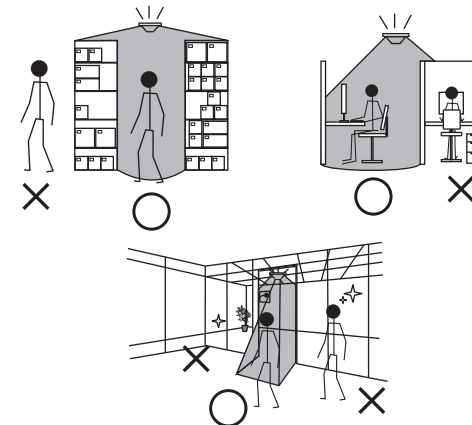

www.irtec.com

P/N: 058-50902-006

Printed in Taiwan

This product may be covered by one or more U.S. patents or patent applications. Please visit www.irtec.com for more information.



CONTROL MODE

The LRD-509 sensor can be programmed by SRP-280 remote programmer to control the lighting in one of the following modes. For more details of specific control mode, please visit www.irtec.com or contact an IR-TEC team member directly.

ON/OFF : ON-OFF Switching

OSO : Occupancy Sensing Only

OSLA : Occupancy Sensing at Low Ambient

OSLATO : Occupancy Sensing at Low Ambient with Time-Off

Mode	Control (LRD-509Sxx)
ON/OFF	<ol style="list-style-type: none"> While ambient lux is higher than the level set, light stays OFF. While ambient lux is lower than the level set, and occupancy detected, switch the light to 100%. Turn OFF the light after occupant leave and delay time elapses.
OSO	<ol style="list-style-type: none"> Ambient light sensor disabled. Dim the light to LOW DIM at all time under vacancy. Switch the light to HIGH DIM under occupancy. Dim the light to LOW DIM after occupant leave and delay time elapses.
OSLA	<ol style="list-style-type: none"> While ambient lux is higher than the level set, light stays OFF. While ambient lux is lower than the level set, dim the light to LOW DIM under vacancy. While ambient lux is lower than the level set, and occupancy detected, switch the light to HIGH DIM Dim the light to LOW DIM after occupant leave and delay time elapses.
OSLATO	<ol style="list-style-type: none"> While ambient lux is higher than the level set, light stays OFF. While ambient lux is lower than the level set, and occupancy detected, switch the light to HIGH DIM. Dim the light to LOW DIM after occupant leave and delay time elapses. Turn OFF the lights when TIME OFF delay elapses. When occupancy detected during TIME OFF, switch the light to HIGH DIM.

SENSOR ACKNOWLEDGMENT

Acknowledgement	Sensor LED	Beep	Lighting
Full sensor setting upload completed	-	Long x 1 Short x 2	Flash x 2
Sensor resume to factory default	-	-	Flash x 2
SmartDIM level set completed	-	Short x 2	Flash x 2
Single setting ok	-	Short x 2	-
Occupancy detected	Flash x 1	-	-

SENSOR SETTINGS

The followings are settings and options available with LRD-509 that can be configured through the operation of SRP-280 remote programmer. For more details of remote sensor setting, please refer to the operation instruction of SRP-280.

Settings	Description	Options (*Denotes factory default.)
CONTROL	The mode that the sensor will control.	ON/OFF, OSO, OSLA, OSLATO*
AMBIENT LUX	The ambient light level that sensor will perform the control.	Setting
		LUX
OFF DELAY	The delay time that sensor is set to turn off or dim the light after the area is vacant.	1/3/5/ 10* /15/20/30/60 min.
TIME OFF	The delay time that sensor will keep the light at low dim level after the OFF delay time elapsed.	3/5/ 10* /15/20/30/45/60 min.
HIGH DIM	The output level set to control the light during occupancy.	50/55/60/65/70/80/90/100%/ SmartDIM*
LOW DIM	The output level set to control the light when the space is vacant.	0/5/10/15/20/25/ 30* /40%
RAMP UP	The speed of increasing the lighting output to HIGH DIM level.	INSTANT*/SOFT/SLOW
FADE DOWN	The speed of decreasing the lighting output to LOW DIM level or off.	INSTANT/ SOFT* /SLOW
SENSITIVITY	The sensitivity of occupancy sensor.	HIGH*/NORMAL/LOW
BURN-IN	The duration of burn-in test.	STOP*/12/24/48/72/96H/MANUAL

WIRING DIAGRAM

Non-dimmable Lighting (ON-OFF Switching only)

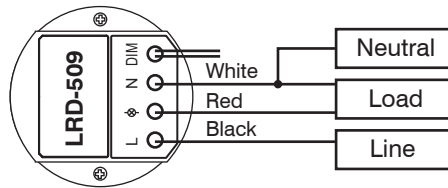

0-10V Dimmable Lighting

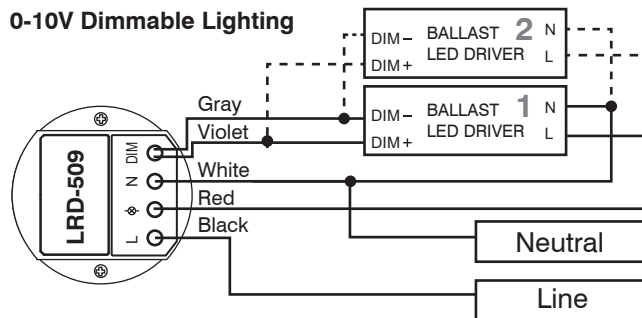

NOTE:

- The driver/ballast MUST be 0-10V dimmable to achieve dimming control.
- Ensure connection of LINE and NEUTRAL are not reversed to avoid damaging the sensor.
- Ensure TOTAL isolation between DIM+/DIM- and GROUND to avoid damaging the sensor.
- Conduct test with GROUND connected.

SPECIFICATIONS

Power supply	100/120/230/277VAC, 50/60 Hz		
Maximum Load	100-120VAC	230VAC	277VAC
	-Incandescent/Halogen	800/*500W(VA)	5A 1200/*750W(VA)
	-Fluorescent Ballast/CFL	800/*500W(VA)	5A 1200/*750W(VA)
-Ballast Electronic (LED)	540/*500VA	5A	1200/*750VA
Infrared sensor	Omni-directional quad element pyroelectric		
Photo sensor	Digital ambient light sensor		
HIC protection	Max. 80A for 16.7msec.		
Dim control output	0-10V, non-isolated, max. 25 mA		
Detectable speed	0.3 ~ 3 m/sec. (1~10 ft./sec.)		
Mounting height	Subject to the lens type applied.		
Detection range	Subject to the lens type and mounting height		
Remote range	10m (33 ft.) indoor, no backlight		
Op. humidity	Max. 95% RH		
Op. temperature	-40°C~70°C (-40°F~158°F)		
Dimensions	Ø60 x H37mm (Ø2.36" x H1.45")		

*Max load for operating temperature at 55°C~70°C (131°F~158°F)