



Specializing in Building Sensors

OS-551/551T

Low Voltage Occupancy Sensor

INSTALLATION INSTRUCTIONS

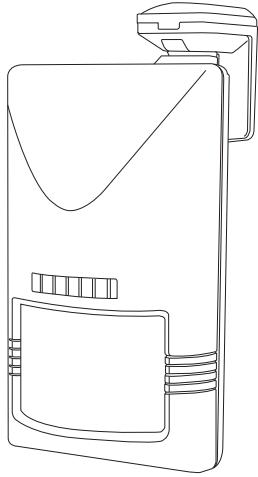

INDOOR USE ONLY

Utilisation à l'interieur Uniquement

CAUTION

- Turn power OFF at circuit breaker before connecting Power Pack or Sensor.
- Wire all Class 2 circuits using types CL3, CL3P, CL3R, or equivalent conductors.

PRUDENCE

- Coupez l'alimentation au disjoncteur avant d'installer Power Pack ou capteurs.
- Câble toute classes 2 circuits CL3, CL39, CL3R ou conducteur équivalent.

OVERVIEW

The OS-551/OS-551T is a low voltage occupancy sensor designed to signal the occupancy status for area lighting, or HVAC control, for energy efficient building management. The sensor is operated by 24VAC/DC power supply from an IR-TEC power pack, or building management system, and provides a dry contact signal for control of the connected lighting or HVAC equipment.

A cutting edge dual element pyroelectric infrared sensor and unique Fresnel lens are employed to provide superior occupancy sensing capability. When the sensor detects an occupant's presence, the relay contact output will be engaged until the OFF-delay time expires. If the sensor is applied to control the operation of HVAC systems, the ON-delay can be enabled to prohibit short-cycle restarting or unwanted load activation. Both ON and OFF delays can be easily set through jumper pin positioning.

In addition to the standard features of OS-551, the OS-551T further provides high/low temperature setbacks to help maintaining room temperature within the range during unoccupied period. The sensor comes with a multi-directional bracket for easy mounting on the ceiling or wall, which also allows horizontal/vertical sensor angle adjustment to achieve optimal coverage.

DIMENSIONS

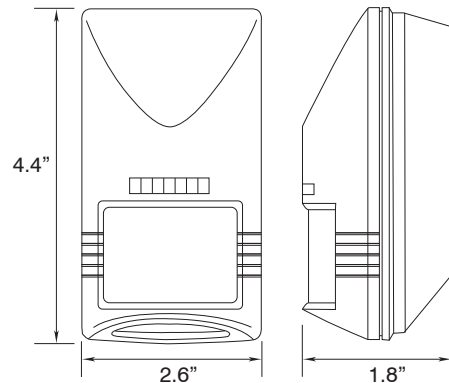

APPLICATION NOTES

1. PIR sensor is more sensitive to the movements "crossing" the detection zones than "toward" or "away" the sensor unit. Avoid placing the sensor in line with the path of occupant, if possible.
2. PIR sensor cannot "see" the movements behind obstacles, such as furniture, shelf, glass or partitions. As a general rule, ensure to place the sensor at where the occupant could have clear view of the sensor.
3. For open office areas with partition which could block the sensor view to occupant movements, it is recommended to place the sensors over the intersection of multiple workstations. For large areas of open office or space, place multiple sensors so that there is overlap coverage with each adjacent sensor.

SPECIFICATIONS

Power supply	24 ± 2 VAC/DC
Current drain	7 mA @24VAC
Output contact	Form C, Max. 30 VDC, 0.2A
Infrared sensor	Dual element pyroelectric infrared sensor
Detectable speed	0.33 ~ 10 ft/sec. (0.1 ~ 3 m/sec.)
Mounting height	6 ~ 12 ft. (1.8 ~ 3.6 m)
Detection range	110°, 50 ft @ 77°F (25°C)
ON delay setting	0(disabled)/10"/30"/1'/5'/10' selectable
OFF delay setting	10"/1'/5'/10'/20'/30' selectable
High/low setback*	High: 85/82/79°F, Low: 59/55/51°F
Op. humidity	Max. 95% RH
Op. temperature	-4°F ~ 122°F (-20°C ~ 50°C)
Dimensions	4.4" x 2.6" x 1.8" (112 x 66 x 45 mm)

*Only available on OS-551T

DETECTION PATTERNS

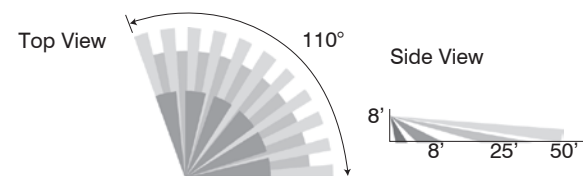

SENSOR OPERATION

The sensor will enter a warm-up period when power is first applied and then operate as described below.

A. Standby mode

The sensor will enter into standby mode after the warm-up period expires. The LED will flash if any jumper is not properly placed on the pin.

B. ON delay mode

If the ON-delay is enabled, the sensor will enter this mode when it first detects the presence of an occupant.

Any further motion detected during the ON-delay mode will NOT reset the timer.

C. 1-minute waiting

When the ON-delay expires, the sensor will enter into the 1-minute waiting period. If no motion is detected within this time period, the sensor will return to standby mode. If motion is detected within this time period, the sensor will engage the relay contact and enter into OFF-delay mode.

D. OFF delay mode

The OFF-delay is the time period that the sensor will hold its relay contact engaged. Every motion detected during this time period will reset the timer. The sensor will return to standby mode if no further motion is detected during this time period and the relay will be disengaged.

Note: The OS-551T will activate its relay contact output automatically when room temperature exceeds the high/low setback range when controlling in an HVAC system.

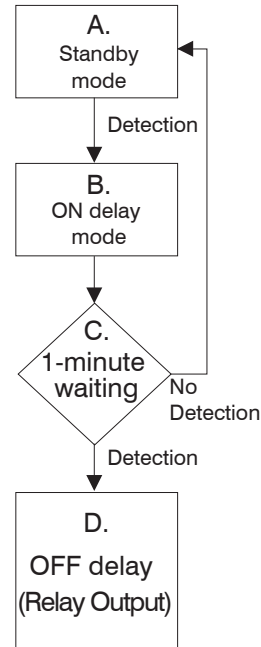

www.irtec.com

P/N: 058-55101-003

Printed in Taiwan

This product may be covered by one or more U.S. patents or patent applications. Please visit www.irtec.com for more information.

WIRING DIAGRAM

The OS-551/551T comes with pigtail wires for connection to the corresponding wires of IR-TEC power pack or BMS control. Each IR-TEC PPU-300/301 power pack can supply power for up to 6 OS-551 sensors. When more sensors are connected, multiple power packs may be required. Various control modes may be achieved by different wiring connections. The following diagrams are typical control for reference. For the availability of more complex control, please contact info@irtec.com for technical assistance.

A. Auto-ON/Auto-OFF with PPU-301

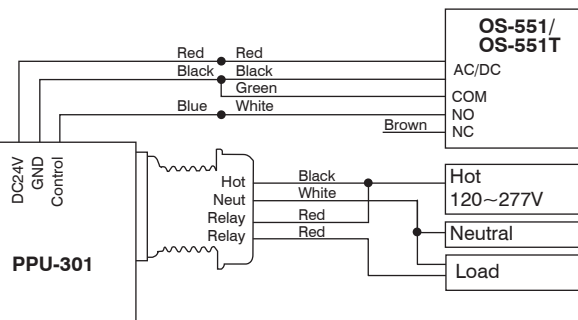

B. Manual-ON/Auto-OFF with PPU-300

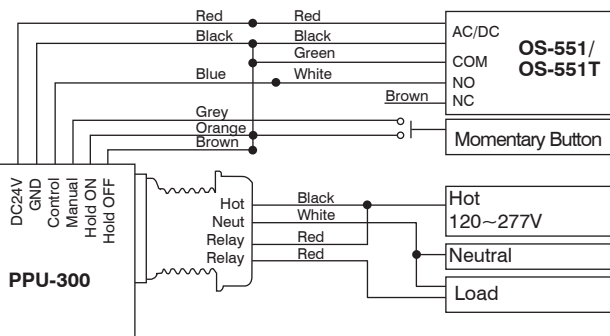

MOUNTING THE SENSOR

The OS-551/551T comes with the bracket assembled which allows it to be mounted on wall or ceiling with two screws. To achieve optimal coverage, sensor angle can be adjusted horizontally or vertically by loosening the tightening screw on the bracket. Ensure to tighten the tightening screw to hold the sensor position.

1. Mount the bracket base to the mounting surface with screws.
2. Drill a proper hole on the mounting surface to lead the sensor wires through.
3. Refer to the wiring diagram and connect the sensor wires to the power pack or BMS control.

Ceiling mount

It is best to leave approximately 6 inches between the sensor and the wall so that the tightening screw can be accessed.

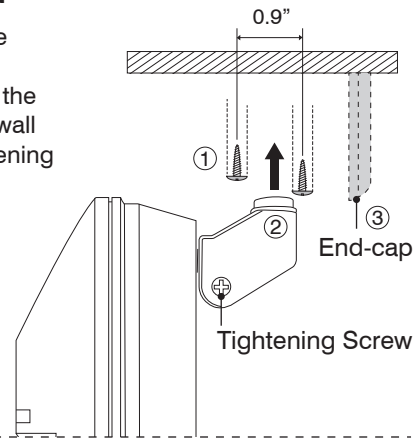

Wall mount

Mount the first screw with approximately 0.3" head-off the wall for ease of base mounting.

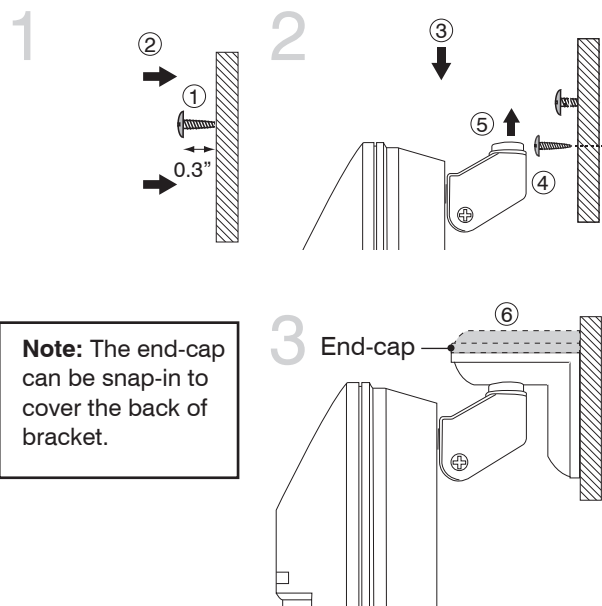

Note: The end-cap can be snap-in to cover the back of bracket.

RANGE TEST

It is recommended to conduct a walk test to verify optimum coverage after sensor installed. To test the sensor range, restore the front cover, apply the low voltage power and wait approximately 60 seconds for sensor to warm up. The LED will blink during warm-up period. Walk into the projected area in the path of occupant show up and observe if the sensor can detect the presence. The LED will be lit whenever sensor detects the motion. If the space has multiple entrances, repeat the test in all available paths.

Note: The OFF-delay can be set to the shortest (position A) for convenience of testing. Ensure to replace the jumper header at the desired position after testing. The LED will blink if any header is NOT properly placed.

RANGE ADJUSTMENT

The detection range can be adjusted by changing the sensor direction to suit for different space or area. To adjust the sensor direction, slightly loosen the tighten screw on the bracket and rotate the sensor unit horizontally or vertically to achieve optimum detection coverage.

ON & OFF DELAYS

ON-delay is the time given to the sensor to inhibit its output to avoid unnecessary HVAC operation activated by walk-through traffics or short stay. OFF-delay is the time the relay output will be engaged after the sensor detects the last motion within its range.

Both ON and OFF delay times can be easily set by placing the header at respective pin position on the sensor board as per following table.

Delay	A	B	C	D	E	F
ON	0	10"	30"	1'	5'	10'
OFF	10"	1'	5'	10'	20'	30'

Factory set

WARRANTY

IR-TEC International Ltd. warranties this product to be free of defects in materials or workmanship for a period of five years from date of shipment. There are no obligations or liabilities on the part of IR-TEC International Ltd. for consequential damages arising out or in connection with the use or performance of this product or other indirect damages with respect to loss of property, revenue, profit, or cost of removal, installation or reinstallation.

SENSOR SETTINGS

OS-551

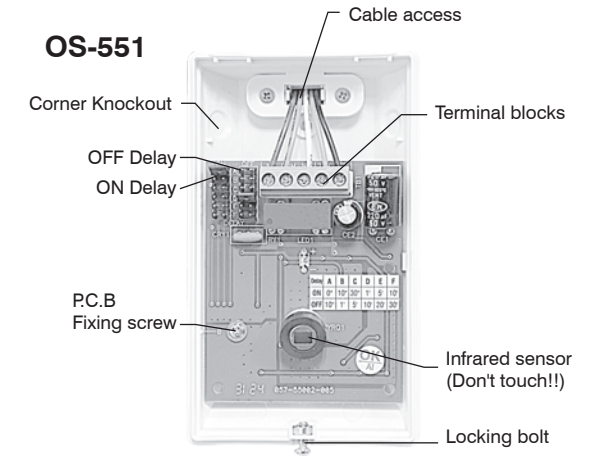

OS-551T

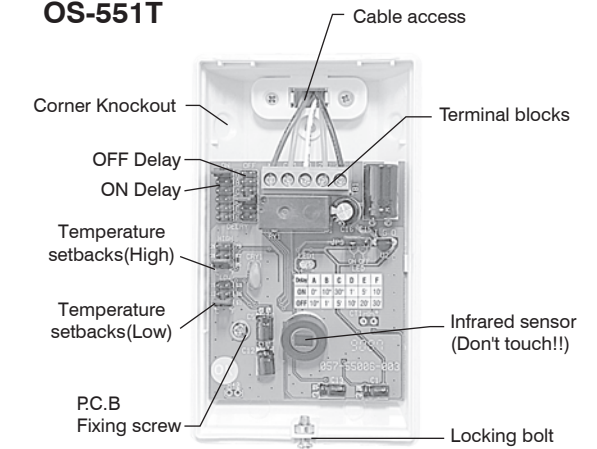

TEMPERATURE SETBACKS

3 different temperatures are available by placing the header at respective position for high and low setbacks setting. When room temperature goes above or below the High or Low limit, the relay output will be activated automatically during vacancy period.