

# WALLSENZR

## BBT-700 Series

Low Voltage Wall Switch Sensor

### INSTALLATION INSTRUCTIONS

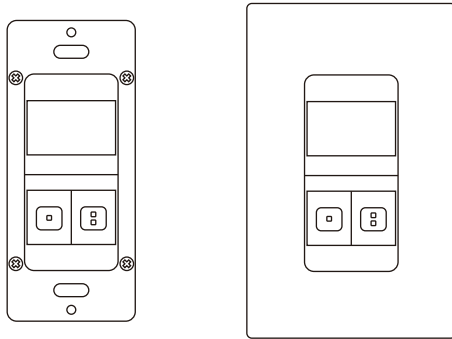

**INDOOR USE ONLY**

**Utilisation à l'intérieur Uniquement**

#### **⚠ WARNING & CAUTION**

- Turn power OFF at circuit breaker before installing Power Pack or Sensors.
- Do NOT touch the square window of infrared sensor under the lens assembly.
- Do Not Install To and/or Cover a Junction Box Having Class 1, 3 or Power and Lighting Circuits
- Class 2 Device Wiring Only – Do Not Reclassify and Install as Class 1, 3 or Power and Lighting Wiring

#### **⚠ AVERTISSEMENT & PRUDENCE**

- Coupez l'alimentation au disjoncteur avant d'installer Power Pack ou capteurs.
- Ne PAS toucher la fenêtre carrée de capteur infrarouge sous l'ensemble de l'objectif
- Ne pas installer ou couvrir une boîte de jonction ayant les classes 1 et 3 ou circuits de puissance et d'éclairage.
- Classe 2 Câblage de périphériques Seulement - Ne PAS reclasser et installer Classe 1, 3 ou alimentation et circuits d'éclairage

### OVERVIEW

The BBT-700 is a member of IR-TEC's WALLSENZR family of 2-pole low voltage wall switch sensor designed to fit in a standard NEMA wall box. The sensors combine state-of-the-art passive infrared sensing technology with décor aesthetics to provide optimal energy-saving for all applications.

The BBT-700 contains two relays, and two push buttons, for controlling two lighting loads or circuits independently together with the connected Power Packs or BMS. To comply with specific energy code, such as CA Title 24, the sensor is factory set to control the primary output (pole 1) in occupancy sensing mode, and the secondary output (pole 2) in vacancy sensing mode. A variety of control options can be programmed via DIP switch settings to meet specific energy code or customer requirements.

The model BBT-700S comes with an ambient light sensor (ALS) to inhibit the lighting if ambient light levels are higher than required. The Accu-Set digital potentiometers make delay time (TIME) and ambient light level (LUX) settings fast, easy and accurate. Isolated dry contact outputs allow the BBT-700 series to operate with two IR-TEC Power Packs for controlling two separate loads in occupancy and vacancy sensing bases.

### DETECTION COVERAGE

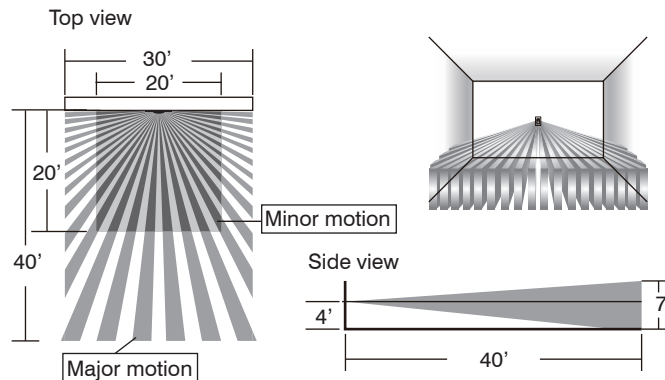

### INSTALLATION NOTES

1. The sensor is more sensitive to the movements "crossing" the detection zones than "toward" or "away" the sensor. To obtain better sensitivity, ensure the sensor to have clear field of view for the occupant's motion within the desired coverage.
2. The closer movement is to the sensor, the more sensitive the sensor is.
3. The sensor should be mounted within the specified mounting height for optimal performance.
4. Avoid blocking the sensor with any obstacles, such as door, plant, partition or furniture. As a general rule, every occupant within the desired range should be able to clearly see the sensor.
5. Do NOT mount the sensor directly above or nearby a heat source, or where unintended motion (e.g. hallway traffic) will be "seen" by the sensor.

### SPECIFICATIONS

Power input	12~24 VDC ± 5%
Current drain	5/30 mA, 24VDC @ vacant/occupied
Infrared sensor	Dual element pyroelectric
Control output	2 x Form A relay, dry contact
Contact rating	Max. 2A @30VDC, isolated
Detectable speed	1~10 ft./sec. (0.3~3 m/sec)
Mounting height	3~5 ft. (90~150 cm) above the floor
Detection coverage	Major motion - 30 ft x 40 ft (W x L) @ 4 ft H Minor motion - 20 ft x 20 ft (W x L) @ 4 ft H
Ambient light level	7 levels, from dark to 24 Hour
Delay time setting	T/1'/3'/5'/10'/20'/30', T=10 sec. for testing
Op. humidity	Max. 95% RH, non-condensate
Op. temperature	-40°F ~ 131°F (-40°C ~ 55°C)
Dimensions	4.13"H x 1.77"W x 1.65"D (w/mounting plate)



www.irtec.com P/N: 058-70003-005

Printed in Taiwan

This product may be covered by one or more U.S. patents or patent applications. Please visit www.irtec.com for more information.



## WIRING DIAGRAM

### • Sensor control ON/OFF (PPU-300/301)

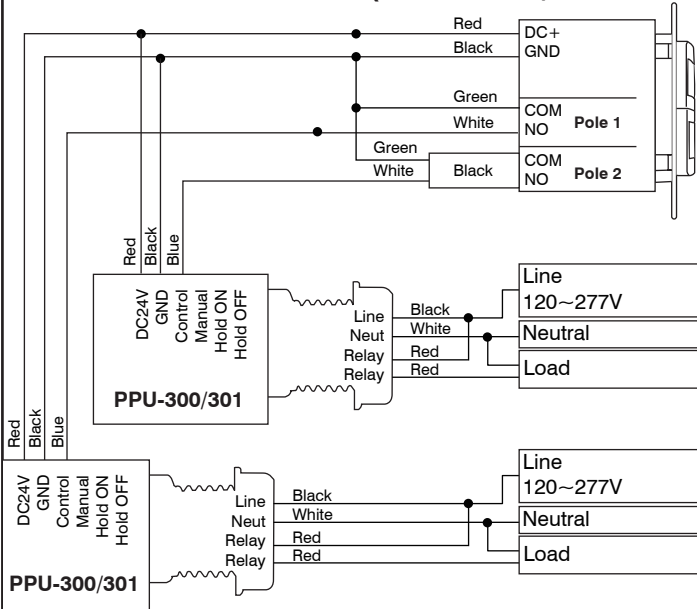

The sensor may be available with other control options, consult a qualified electrician or contact [info@irtec.com](mailto:info@irtec.com) for assistance.

## INSTALLATION

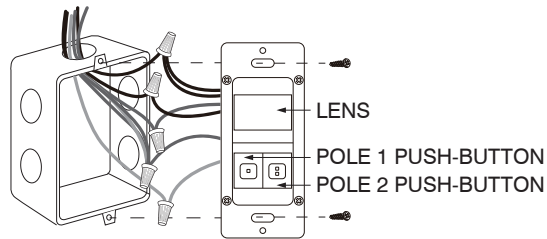

1. Install the power pack and connect the load according to its instructions.
2. Connect the low voltage wires of power pack with the respective wires of the sensor according to the diagram of desired control.
3. Turn ON the line voltage power for the power pack.
4. Conduct sensor operation test.
5. Attach the wallplate cover after testing and setting completed.

## OPERATION

The BBT-700 series low voltage wall switch sensor employs passive infrared (PIR) sensing technology to monitor the occupancy status within its coverage, and provide two isolated dry contact outputs for the connected power packs to control the operation of connected loads. The sensor provides typical occupancy sensing control (Auto-ON, Auto-OFF) on pole 1, and vacancy sensing control (Manual-ON, Auto-OFF) on pole 2. Different control modes of each pole can be achieved through DIP switch settings. Presentation Mode (PM) allows the occupant to switch off the load as desired by pressing the specific push-button. The load will remain off if motion is detected before the time delay elapses. Pressing the push-button again will turn the load back ON and the sensor will operate as per sensor setting. If no motion has been detected and the time delay expires, sensor will return to normal operation and turn on the load with the next sensed motion.

To program the sensor operation mode or change the settings, press the push-button cover and slide it down as shown.

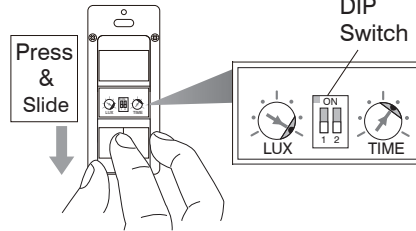

## SETTING

The BBT-700 series provides 7 different delay time and ambient light level settings via rotating the Accu-Set potentiometers at respective position as table below.

POS.	1	2	3	4	5	6	7
TIME	T	1'	3'	5'	10'	20'	30'
LUX	5	10	30	50	100	150	24H

Factory Set

## TIME - Delay time

This is the delay time that the BBT-700 series sensor will hold the load ON after the last motion detected. The factory setting is 10 minutes, and it can be changed by pointing the arrowhead of potentiometer to the specific position.

## LUX - Ambient light level

This is the threshold of ambient light level that the sensor will inhibit switching ON the load. The factory setting is ALS disabled (24 Hr) for ease of testing, and it can be changed by pointing the arrowhead of potentiometer to the specific position.

## TESTING

After the sensor installed and wiring completed, sensor operation test can be conducted as instructed below;

1. Apply the power to the Power Pack.
2. Walk within the desired coverage. LED will blink to indicate the motion sensed.
3. Replace the wall plate cover after completing the sensor test and setting.

**NOTE:** The connected load will be switched ON as delay time set (factory default 10 minutes) once apply the power. The delay time can be set to the shortest (10 seconds) for ease of testing. **Ensure to set the TIME as desired for optimum operation after testing.**

## Control Mode

### Pole-1 Control Mode - SW1

#### Occupancy Sensing with ALS Control (OSAC)

Sensor will turn ON the load of pole-1 when it detects the presence of occupant, and turn OFF automatically if no occupant motion is detected before the time delay elapses. The ambient light sensor (ALS) will inhibit switching ON the load if ambient light level is higher than the set threshold.

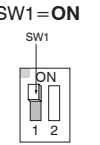

#### Occupancy Sensing with ALS & PM (OSAP)

Sensor will control the load of pole-1 as in OSAC, but with ALS and Presentation Mode (PM) both active.

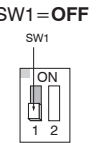

### Pole-2 Control Mode - SW2

#### Vacancy Sensing Only Control (VSOC)

VSOC requires occupant to press the pole-2 push-button to turn ON the connected load of pole-2, and sensor will automatically switch OFF the load if no occupant motion is detected before the time delay elapses.

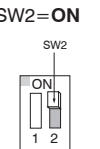

**NOTE:** The sensor will automatically turn ON the light if it detects occupant activity within 30 seconds after time delay elapsed.

#### Ambient Light Sensing Only (ALSO)

The sensor will automatically turn ON the connected load of pole-2 when ambient light is lower than the LUX level set, and turn OFF the load automatically when ambient light is higher than the threshold set.

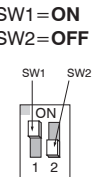

#### Pole One with Extended Delay (POED)

The sensor will control the load of pole-2 as per pole-1 is set, but with an Extended Delay for 5 minutes.

