

# WALLSENZR

## BDT-700 Series

Low Voltage Dual-Tech Wall Switch Sensor

### INSTALLATION INSTRUCTIONS

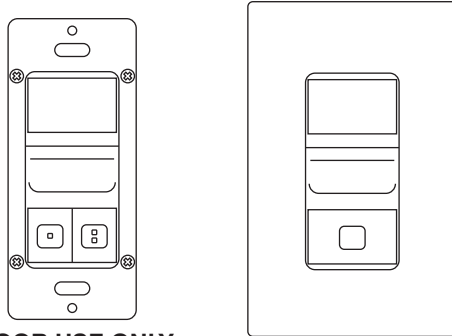

**INDOOR USE ONLY**

Utilisation à l'interieur Uniquement

### ⚠ WARNING & CAUTION

- Turn power OFF at circuit breaker before installing Power Pack or Sensors.
- Do NOT touch the square window of infrared sensor under the lens assembly.
- Do Not Install To and/or Cover a Junction Box Having Class 1, 3 or Power and Lighting Circuits.
- Class 2 Device Wiring Only – Do Not Reclassify and Install as Class 1, 3 or Power and Lighting Wiring.

### ⚠ AVERTISSEMENT & PRUDENCE

- Coupez l'alimentation au disjoncteur avant d'installer Power Pack ou capteurs.
- Ne PAS toucher la fenêtre carrée de capteur infrarouge sous l'ensemble de l'objectif.
- Ne pas installer ou couvrir une boîte de jonction ayant les classes 1 et 3 ou circuits de puissance et d'éclairage.
- Classe 2 Câblage de périphériques Seulement - Ne PAS reclasser et installer Classe 1, 3 ou alimentation et circuits d'éclairage.

#### FCC NOTICE

This device complies with Part 15 of the FCC Rules. Operation is subject to the following two conditions:  
 (1) This device may not cause harmful interference,  
 (2) This device must accept any interference received, including interference that may cause undesired operation.

Install the sensor at least 1ft. away from any occupant.

### OVERVIEW

The BDT-700 series is a 2-pole dual technology low voltage wall switch sensor designed to fit in a standard NEMA wall box for automatic lighting control. This state-of-the-art wall switch sensor combines digital Passive Infrared (PIR) and advanced High Frequency Doppler (HFD) sensing technologies into an aesthetically pleasing housing to provide excellent occupancy/vacancy sensing performance within its 180° field of view detection range.

The BDT-700Sx contains two isolated dry contacts, and two push buttons, for controlling two lighting loads or circuits independently via the connected Power Packs or BMS. A dual color LED indicates the status of sensor detection, BLUE for PIR and GREEN for HFD. Pressing the push-button will change the state of relay contacts manually. The sensor provides typical occupancy sensing (Auto-ON, Auto-OFF) control on pole-1 and vacancy sensing (Manual-ON, Auto-OFF) control on pole-2. Different control modes of each pole can be programmed via DIP switch settings. Presentation Mode (PM) allows the occupant to switch off the load as desired by pressing the specific push-button. The load will remain off if motion is detected before the time delay elapses. Pressing the push-button again will turn the load back ON and the sensor will operate as per sensor setting. If no motion has been detected and the time delay expires, sensor will return to normal operation and turn on the load with the next sensed motion.

### DETECTION COVERAGE

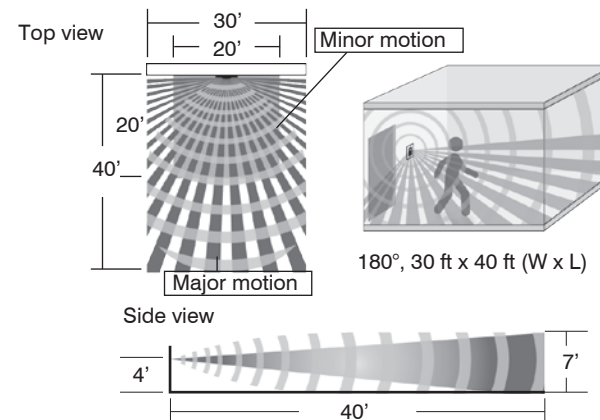

### INSTALLATION NOTES

1. The PIR sensor is more sensitive to the movements "crossing" the detection zones than "toward" or "away" it. To obtain better sensitivity, ensure the sensor to have clear field of view for the occupant's motion within the desired detection coverage.
2. In general, the HFD sensor has better sensitivity to the minor motions than the PIR sensor. The HFD sensor could possibly detect the movements out of sight through non-metallic partition or enclosure. If so, reduce the HFD sensitivity to prevent unwanted triggering.
3. The sensor should be mounted within the specified mounting height to achieve optimal performance.
4. Do NOT mount the sensor directly above or nearby a heat source, or where unintended motion (e.g. hallway traffic) will be "seen" by the sensor.

### SPECIFICATIONS

Power input	12~24VDC ± 5%
Current drain	10/40 mA, 24VDC @vacant/occupied
Sensing technology	Digital PIR & High Frequency Doppler
Control output	2 x form A relay, isolated dry contact
Contact rating	Max. 2A @30VDC, isolated
Detectable speed	1~10 ft./sec. (0.3~3 m/sec)
Mounting height	3 ~ 5 ft. (90~150 cm) above the floor
Detection coverage	Major motion - 30 ft x 40 ft (W x L) @4 ft high Minor motion - 20 ft x 20 ft (W x L) @4 ft high
Ambient light level	7 levels, from dark to 24 Hr. (ALS disabled)
Delay time setting	T/1'/3'/5'/10'/20'/30', T=10 sec. for testing
Op. humidity	Max. 95% RH, non-condensate
Op. temperature	-40°F ~ 131°F (-40°C ~ 55°C)
Dimensions	4.13"H x 1.77"W x 1.65"D (w/mounting plate)



www.irtec.com

P/N: 058-70007-003

Printed in Taiwan

This product may be covered by one or more U.S. patents or patent applications. Please visit [www.irtec.com](http://www.irtec.com) for more information.



## WIRING DIAGRAM

### • Sensor control ON/OFF (PPU-300/301)

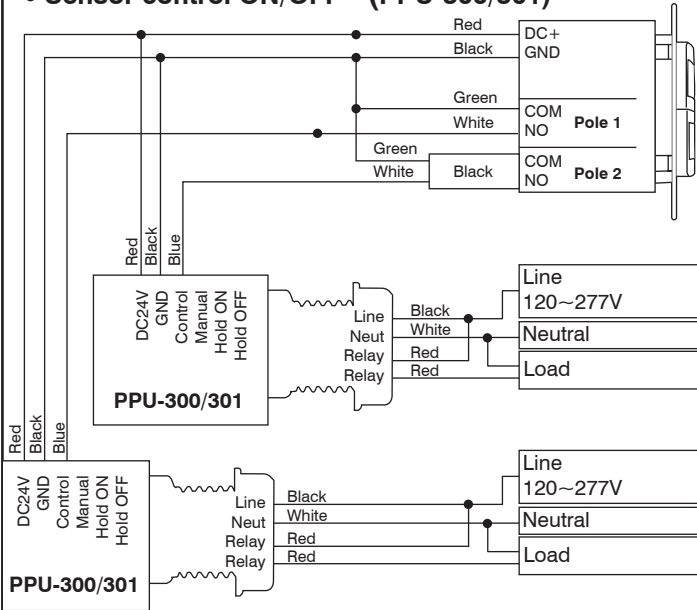

The sensor may be available with other control options, consult a qualified electrician or contact [info@irtec.com](mailto:info@irtec.com) for assistance.

## INSTALLATION

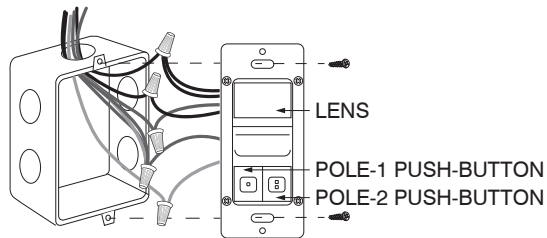

1. Install the power pack and connect the load according to its instructions.
2. Connect the low voltage wires of power pack with the respective wires of the sensor according to the diagram of desired control.
3. Turn on the line voltage power for the power pack.
4. Conduct sensor operation test.
5. Attach the wallplate cover after testing and setting completed.

## SETTING

To program the sensor control mode or change the settings, press the push-button cover and slide it down as shown.

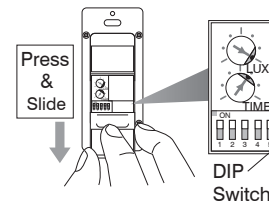

### TIME - Delay time

TIME setting determines the delay time that the sensor will hold the load ON after the last motion detected. Factory setting is 10 minutes, and it can be changed by pointing the arrowhead of potentiometer to the specific position.

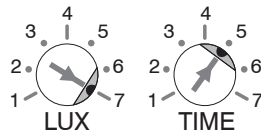

POS.	1	2	3	4	5	6	7
TIME	T	1'	3'	5'	10'	20'	30'
LUX	10	20	35	50	100	150	24H

Factory Set

### LUX - Ambient light level

LUX setting determines the threshold of ambient light level that the sensor will inhibit switching on the load. The factory setting is ALS disabled (24 Hr) for testing convenience, and it can be changed by pointing the arrowhead of potentiometer to the specific position.

## TESTING

1. Restore the line power for sensor operation and wait for the sensor to warm-up (GREEN LED will blink during the warm-up period).
2. Move within the desired range and observe the sensor detection. BLUE blink indicates the PIR sensor detected, and GREEN blink indicates the HFD sensor detected. Move outside of the desired range and observe if the HFD sensor can detect. If GREEN LED blinks, reducing the HFD sensitivity accordingly.
3. Replace the wall plate cover after sensor testing and setting completed.

**NOTE:** The connected load will be switched ON as delay time set (factory default 10 minutes) after the power applied. The delay time can be set to the shortest (10 seconds) for test convenience. **Ensure to set the TIME back to the desired delay for optimum operation after test.**

## DIP Switch

### HFD Sensitivity - SW1 & 2

The combinations of DIP switch 1 and 2 determine the sensitivity of HFD sensor.

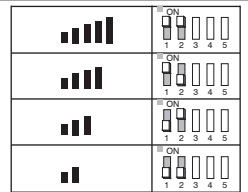

### Operating Sensor - SW3

DIP switch 3 changes the operating sensor. If necessary, the BDT-700 can be programmed as a single HFD wall switch sensor.



### Pole-1 Control Mode - SW4

#### Occupancy Sensing with ALS Control (OSAC)

Sensor will turn ON the load of pole-1 when it detects the presence of occupant, and turn OFF automatically if no occupant motion is detected before the time delay elapses. The ambient light sensor (ALS) will inhibit switching ON the load if ambient light level is higher than the set threshold.

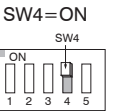

#### Occupancy Sensing with ALS & PM (OSAP)

Sensor will control the load of pole-1 as in OSAC, but with ALS and Presentation Mode (PM) both active.

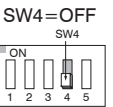

### Pole-2 Control Mode - SW5

#### Vacancy Sensing Only Control (VSOC)

VSOC requires occupant to press the pole-2 push-button to turn ON the connected load of pole-2, and sensor will automatically switch OFF the load if no occupant motion is detected before the time delay elapses.

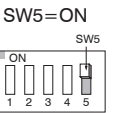

**NOTE:** The sensor will automatically turn ON the light if it detects occupant activity within 30 seconds after time delay elapsed.

#### Ambient Light Sensing Only (ALSO)

The sensor will automatically turn ON the connected load of pole-2 when ambient light is lower than the LUX level set, and turn OFF the load automatically when ambient light is higher than the threshold set.

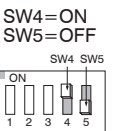

#### Pole One with Extended Delay (POED)

The sensor will control the load of pole-2 as per pole-1 is set, but with an Extended Delay for 5 minutes.

