

WALLSENZR

BDS-702 Series

Low Voltage Dual-Tech Wall Switch Sensor

INSTALLATION INSTRUCTIONS

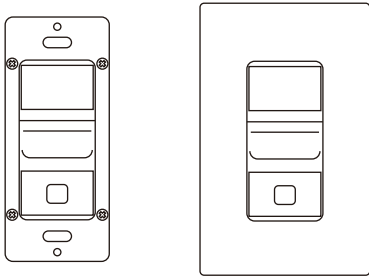

INDOOR USE ONLY

Utilisation a L'interieur Uniquement

WARNING & CAUTION

- Turn power OFF at circuit breaker before installing Power Pack or Sensors.
- Do NOT touch the square window of infrared sensor under the lens assembly.
- Do Not Install To and/or Cover a Junction Box Having Class 1, 3 or Power and Lighting Circuits
- Class 2 Device Wiring Only – Do Not Reclassify and Install as Class 1, 3 or Power and Lighting Wiring

AVERTISSEMENT & PRUDENCE

- Coupez l'alimentation au disjoncteur avant d'installer Power Pack ou capteurs.
- Ne PAS toucher la fenêtre carrée de capteur infrarouge sous l'ensemble de l'objectif.
- Ne pas installer ou couvrir une boîte de jonction ayant les classes 1 et 3 ou circuits de puissance et d'éclairage.
- Classe 2 Câblage de périphériques Seulement - Ne PAS reclasser et installer Classe 1, 3 ou alimentation et circuits d'éclairage..

FCC NOTICE

This device complies with Part 15 of the FCC Rules. Operation is subject to the following two conditions:
(1) This device may not cause harmful interference,
(2) This device must accept any interference received, including interference that may cause undesired operation.

Install the sensor at least 1ft. away from any occupant.

OVERVIEW

The BDS-702 series low voltage dual-tech wall switch sensor employs passive infrared (PIR) and High Frequency Doppler (HFD) sensing technologies to monitor the occupancy status within its coverage, and provide an isolated dry contact output for the connected power pack to control the operation of connected load.

The sensor is factory set to turn ON the load automatically when PIR sensor detects the presence of an occupant, and will turn OFF automatically if no motion is detected by either PIR or HFD sensor before the delay time elapses. The sensor comes with an ambient light sensor (ALS) to inhibit its output if ambient light level is higher than the threshold set. An independent push-button control output can be applied to achieve Multi-way Manual Control (MMC). The sensor with MMC capability is ideal for applications that require multiple sensors to cover the whole area, but still require manual on/off control via wall switch sensors.

DETECTION COVERAGE

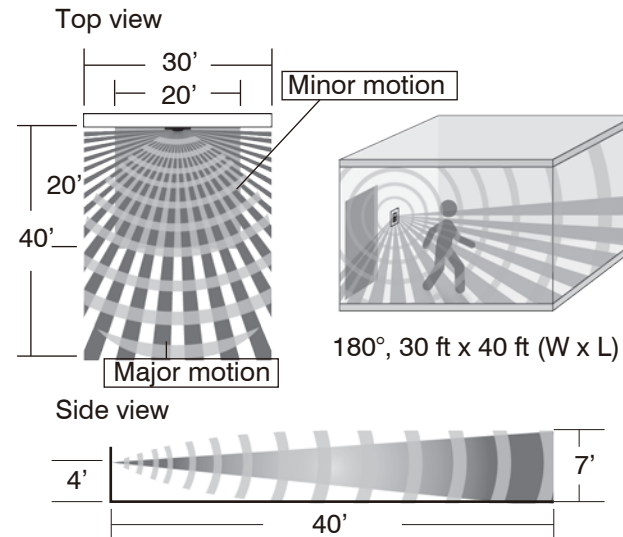

INSTALLATION NOTES

1. The PIR sensor is more sensitive to the movements “crossing” the detection zones than “toward” or “away” it. To obtain better sensitivity, ensure the sensor to have clear field of view for the occupant’s motion within the desired detection coverage.
2. In general, the HFD sensor has better sensitivity to the minor motions than the PIR sensor. The HFD sensor could possibly detect the movements out of sight through non-metallic partition or enclosure. If so, reduce the HFD sensitivity to prevent unwanted triggering.
3. The sensor should be mounted within the specified mounting height to achieve optimal performance.
4. Do NOT mount the sensor directly above or nearby a heat source, or where unintended motion (e.g. hallway traffic) will be “seen” by the sensor.

SPECIFICATIONS

Power input	12~24VDC ± 5%
Current drain	10/30 mA, 24VDC @vacant/occupied
Sensing technology	Digital PIR & High Frequency Doppler
Control output	Form A dry contact & Active low
Contact rating	Max. 2A @30VDC
Detectable speed	1~10 ft./sec. (0.3~3 m/sec)
Mounting height	3 ~ 5 ft. (90~150 cm) above the floor
Detection coverage	Major motion - 30 ft x 40 ft (W x L) @4 ft high Minor motion - 20 ft x 20 ft (W x L) @4 ft high
Ambient light level	7 levels, from dark to 24 Hr. (ALS disabled)
Delay time setting	T/1'/3'/5'/10'/20'/30', T=10 sec. for testing
Op. humidity	Max. 95% RH, non-condensate
Op. temperature	-40°F ~ 131°F (-40°C ~ 55°C)
Dimensions	4.13"H x 1.77"W x 1.65"D (w/mounting plate)



www.irtec.com

P/N: 058-70202-002

Printed in Taiwan

This product may be covered by one or more U.S. patents or patent applications. Please visit www.irtec.com for more information.



WIRING DIAGRAM

The sensor can be applied to provide occupancy sensing control (Auto-ON, Auto-OFF) or vacancy sensing control (Manual-ON, Auto-OFF) through specific wiring as below.

• Occupancy Sensing Control with MMC

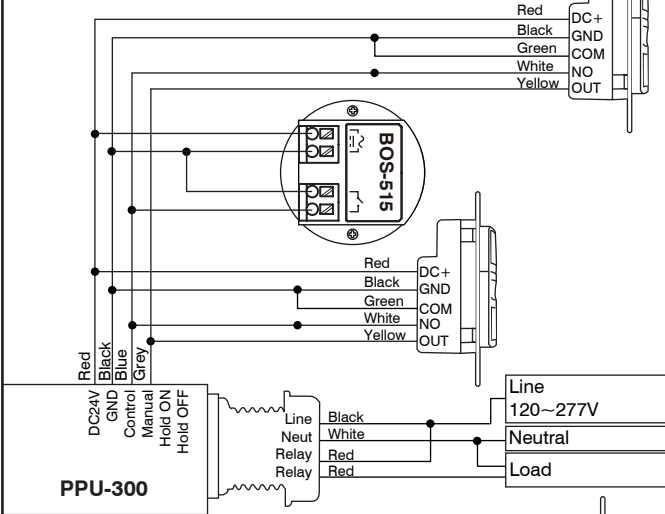

• Vacancy Sensing Control with MMC

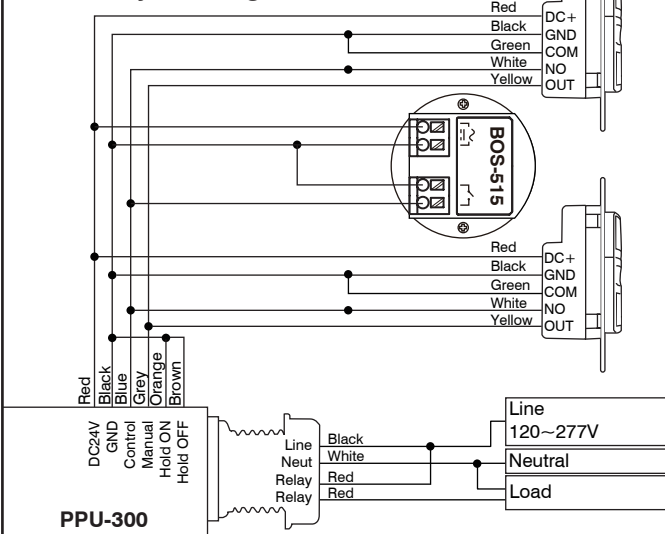

NOTE: The colors of sensor wires do not necessarily match with the wires of power pack for connection. Properly label the wires will help ensure correct wiring.

Other IR-TEC low voltage occupancy sensor may be applicable, please contact sales team for more information.

INSTALLATION

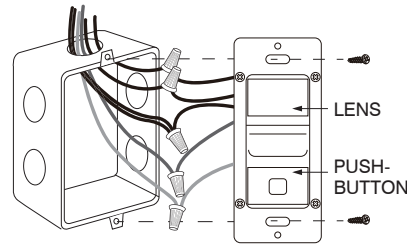

1. Lead the low voltage wires from the wall box to the junction box that the power pack will be installed.
2. Connect the sensor wires with the power pack according to the wiring diagram of desired control. Mount the sensor into the wall box with screws provided.
3. Connect the line voltage wires of the power pack to the load and line voltage power as instructed.
4. Turn on the line voltage power to the power pack, and conduct the sensor operation and control test.

SENSOR SETTINGS

The BDS-702S also features ambient light sensor to inhibit unnecessary lighting when ambient light is higher than the level set. The time delay (TIME) and ambient light level (LUX) settings can be changed by rotating the respective Accu-Set potentiometer at different positions. Via DIP switch setting, the BDS-702S can be programmed to change the HFD sensitivity, operate as a dual or single technology sensor, control the load as an Occupancy Sensor or Vacancy Sensor, and enable/disable the LED indicator.

To program the sensor operation mode or change the settings, press the push-button cover and slide it down as shown.

DIP Switch Settings

HFD Sensitivity - SW1 & 2

The combinations of DIP switch 1 and 2 determine the sensitivity of HFD sensor.



Sensing Technology - SW3 & 4

The combinations of DIP switch 3 and 4 set the operating sensing technology of the sensor.

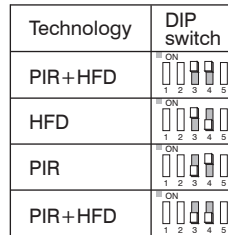

LED Enabled/Disabled - SW5

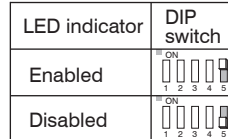

To change the sensor settings, press the push-button cover and slide it down as shown.

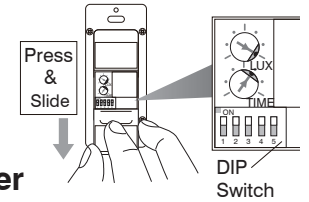

SETTING - Potentiometer

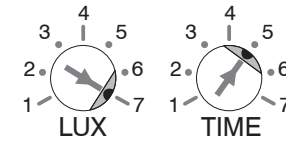

POS.	1	2	3	4	5	6	7
TIME	T	1'	3'	5'	10'	20'	30'
LUX	5	10	30	50	100	150	24H

Factory Set

TIME - Delay time

TIME setting determines the delay time that the sensor will hold the load on after the last motion detected. Factory setting is 10 minutes, and it can be changed by pointing the arrowhead of potentiometer to the specific position.

NOTE: For test convenience, TIME potentiometer can be adjusted to position 1 for the shorten delay (10 seconds). **The sensor will automatically return to the factory default delay (10 minutes) if the potentiometer has not been set to other position within 10 minutes.**

LUX - Ambient light level

LUX setting determines the threshold of ambient light level that the sensor will inhibit switching on the load. The factory setting is ALS disabled (24 Hr) for testing convenience, and it can be changed by pointing the arrowhead of potentiometer to the specific position.

NOTE: If multiple sensors are connected, the LUX settings of all sensors in the same area should be adjusted to the same ambient light level position to achieve coordinated control.

TESTING

After the sensor installed and wiring completed, sensor operation test can be conducted as instructed below;

1. Apply the power to the Power Pack. Wait for the sensor to warm-up.
2. Move within the desired range and observe the sensor detection. BLUE blink indicates the PIR sensor detected, and GREEN blink indicates the HFD sensor detected. Move outside of the desired range and observe if the HFD sensor can detect. If GREEN LED blinks, reduce the HFD sensitivity via changing the DIP switch setting as instructed above. Replace the wall plate cover after completing the sensor test and setting.
3. Replace the wall plate cover after sensor testing and setting completed.