

BDS-610 series

Low Voltage Dual-Tech Occupancy Sensor



OVERVIEW

The BDS-610 series member of the TRANS family is a low voltage dual-tech occupancy sensor designed for energy efficient lighting control. This sensor combines digital Passive Infrared (PIR) and state-of-the-art High Frequency Doppler (HFD) sensing technologies into an aesthetically pleasing, installer friendly, low profile housing to provide second-to-none occupancy sensing performance for today's sustainable buildings.

The sensor provides an isolated dry contact output for load switching through a Power Pack or a Building Management System. In addition, the sensor employs a digital ambient light sensor to inhibit the output when ambient light level is higher than the threshold set. The digital Accu-Set potentiometers make delay time and lux level settings fast, easy and accurate. Numerous types of lens can be applied to offer different PIR sensing ranges required for all applications. The sensitivity of HFD sensor can be adjusted if necessary.

Push-in terminal block enables an easy and direct wiring connection. A unique mounting bracket with snap-on clip makes the sensor installation an easy job. With the BDS-610 series sensor, you can easily deliver an occupancy sensing based lighting/HVAC control to all applications.

FEATURES

- Omni-directional digital quad element infrared
- Advanced High Frequency Doppler module
- Digital data control ambient light sensor built-in
- 12~24VDC low voltage power supply operation
- Isolated dry contact output for versatile control
- Accu-Set potentiometer TIME and LUX settings
- Bi-color LED indicator for walk test verification
- Available with interchangeable lens selection
- Push-in wire locking terminals for easy wiring

APPLICATION

The BDS-610 occupancy sensor can be used to control area lighting or HVAC with an IR-TEC power pack or in connection with building management systems. Various control modes can be achieved by different wiring connections. Consult with an IR-TEC team member for the assistance of more complex controls.

- Lighting Control
- HVAC Control
- Building Management

BDS-610 series

Low Voltage Dual-Tech Occupancy Sensor

TRANS

OPERATIONS

With 12-24 VDC power supplied, the BDS-610 will activate its output when PIR sensor detects the presence of occupant. The delay time starts and HFD sensor will start operating to detect minor motion within the range. The output will be continuously engaged if PIR or HFD detects the motion of occupant. The sensor output can be set to inhibit when ambient light level is higher than the threshold. Sensor will disengage the output if no motion is detected before the delay time elapses.

Lens Options

Different lens options can be applied to provide different coverage at different mounting heights (H). When adding the lens code on the sensor model number, the lens is then automatically shipped with the sensor.

	Lens	Shape	Mounting Height		Coverage
A	Standard	Cone	8~15 ft.	2.4~4.5m	2X height
B	Extra wide	Cone	8~10 ft.	2.4~3.0m	6X height
C	High bay	Cone	15~30 ft.	4.5~9.0m	3X height
D	Standard	Round	8~20 ft.	2.4~6.0m	2X height
F	Extra wide	Dome	8~20 ft.	2.4~6.0m	4X height
G	Aisle way	Arch	8~40 ft.	2.4~12.0m	3X height

DETECTION PATTERN

Top View

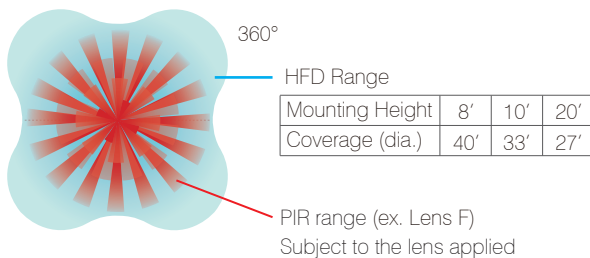

Side View

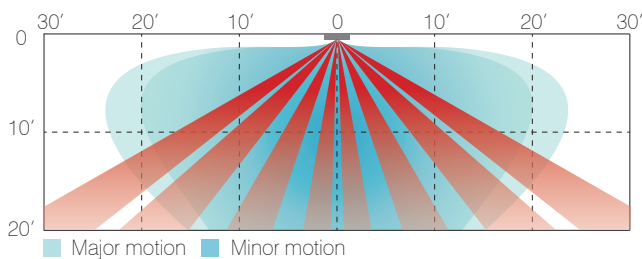

Wiring Diagram

A. Building Management System control

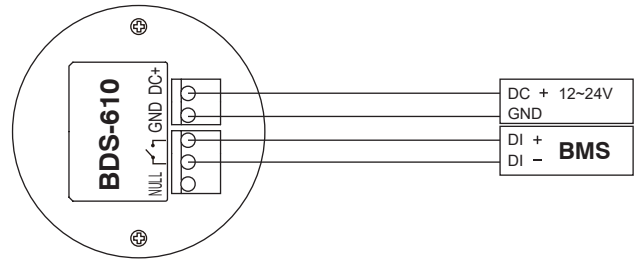

B. Power Pack control

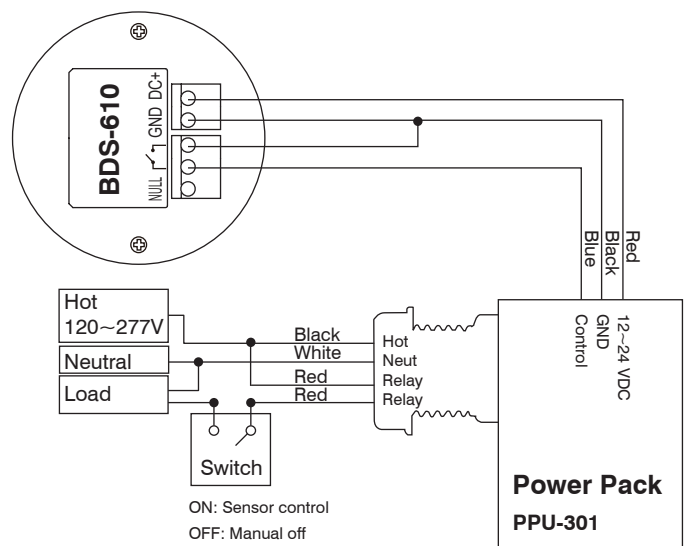

SPECIFICATIONS

Power supply	12~24 VDC±5%
Current drain	20/45 mA@24VDC, vacant/occupied
Motion sensor	Digital PIR & High Frequency Doppler
Light sensor	Digital, color temperature compensation
Control output	Form A relay, NO, dry contact
Contact rating	30VDC, 2.0A max. isolated
Detectable speed	0.5~10 ft./sec. (0.15~3 m/sec)
Mounting height	8~20 ft. (2.4~6 m)
Detection range	Subject to the lens applied and height
Delay time	T/1/3/5/10/20/30 min. T:10 sec. for test
Ambient light level	5/10/30/50/100/200/24H lux & disabled
HFD sensitivity	40~100% adjustable
Op. humidity	Max. 95% RH
Op. temperature	14°F~122°F (-10°C~50°C)
Dimensions	∅4.33"x H1.0" (∅110 x H25 mm)

www.irtec.com

1-855-GO-IRTEC

DS-BDS610-EN-LS_V1 (2016-4)

IR-TEC
Specializing in Building Sensors