

## BED-500 series

### Low Voltage SmartDIM Daylight Sensor

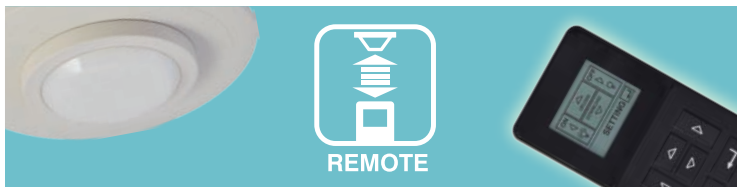
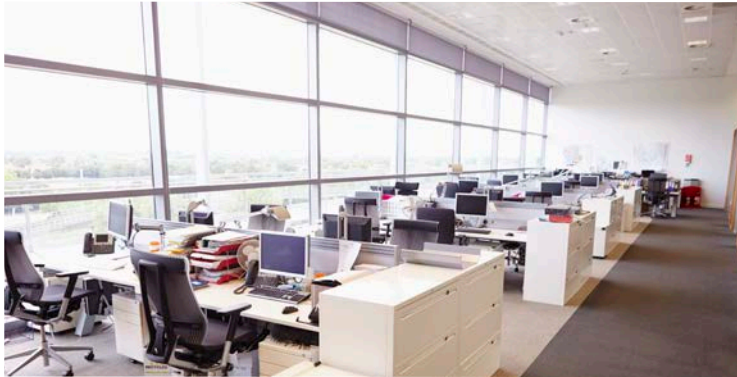

#### OVERVIEW

The BED-500 series member of the TRANS family is a two-way IR programmable low voltage daylight sensor designed for daylight harvesting control. The sensor is able to continuously measure the ambient light level in the target area, provide an isolated dry contact output for light switching together with a 0-10V output for dimmable ballast or LED driver to achieve multi-level high/low dim or SmartDIM control. SmartDIM is a state-of-the-art automatic dimming control technology developed by IR-TEC, which is capable of maintaining the overall ambient light level within the preset range through continuous dimming the connected lights.

This daylight sensor employs a cutting edge digital ambient light sensor (ALS) with an advanced algorithm to provide closed loop, dynamic ambient light level sensing capability. Different mode can be programmed to control the light based on light level sensing automatic on/off or with virtual midnight bi-level control. All sensor settings can be remotely programmed by a bi-directional IR remote programmer on the floor via intuitive keypad operation. This 2-way remote setting capability does away with the need for ladders, scissor lifts, bucket trucks or any other tools.

Like all TRANS family, the BED-500 series is also available in various mounting options. This design innovation offers second-to-none installation flexibility for daylight harvesting control applications in sustainable buildings.

#### FEATURES

- Digital data control ambient light sensor
- Human-eye matching spectral response
- 12~24VDC low voltage power operation
- 2-way IR remote programming capability
- Provide 0-10V dim control analog output
- Isolated dry contact for switching control
- SmartDIM continuous dimming technology
- Virtual Midnight for outdoor lighting control
- Upload success flash acknowledgement
- Available with variety of mounting options

#### APPLICATIONS

The BED-500 series daylight sensor can be used in various applications to meet the requirements for daylight harvesting in areas defined as daylight control zones.

- Commercial
- Educational
- Industrial/Retail
- Public buildings

# BED-500 series

## Low Voltage SmartDIM Daylight Sensor

### 1. Daylight Sensing Control (DSC)

#### SmartDIM

With SmartDIM enabled under DSC (factory default), the sensor will constantly measure the ambient light level and dynamically adjust its 0-10V dim control output to maintain the overall ambient light level within preset range. If the ambient light level exceeds the force-off threshold for a period of time, the sensor will disengage its relay contacts for maximum energy saving.

#### Automatic On/Off

The sensor can be programmed to control the light in typical automatic on/off under DSC mode. When the ambient light level is lower than the ON threshold, the sensor will engage its relay contacts together with dim control output as set, and disengage if the ambient light level is higher than the OFF threshold for a period of time.

### 2. Daylight Sensing Virtual Midnight (DSVM)

DSVM is a smart control solution for outdoor lighting to achieve maximum energy savings. With DSVM control enabled, the sensor will calculate a hypothetical Virtual Midnight (VM) point by sensing the daylight level of dusk and dawn time. The lighting output can be automatically reduced from high to low dim level, starts from a specific time before VM to another specific time after VM. The time before (Tb) and time after (Ta) VM can be separately programmed according to the application and control requirements.

### Mounting Options

The BED-500 series can be mounted into the ceiling, attached to a fixture or mounted into a junction box to control the connected lighting. Different mounting option is available by combining with specific mounting bracket from the chart below. The bracket will be shipped with the sensor when ordered with the respective code. Mounting option code F and W allow the BED-500S $\times$  sensor to be integrated with OEM light fixture for indoor or wet location.

Code	Mounting Option	Mounting Bracket
F	Fixture Integrated	---
W*	IP-66 Fixture Integrated	---
E	Fixture External	EMB-500
P*	IP-66 Fixture External	PMB-500
S	Ceiling Surface	SMB-500
C	Junction Box	CMB-500
R	Ceiling Recess	RMB-500

\*Available for IP-66 fixture integration

### Wiring Diagram

Basic wiring diagrams are included for general reference. Consult with an IR-TEC team member if a more complex wiring diagram is required.

#### • Standalone Fixture Control

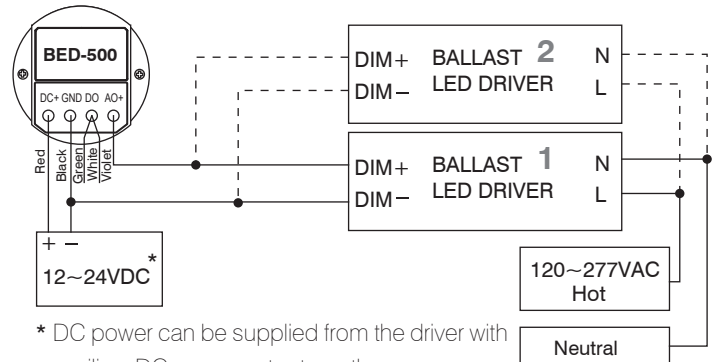

\* DC power can be supplied from the driver with auxiliary DC power output or other source.

#### • Power Pack Control

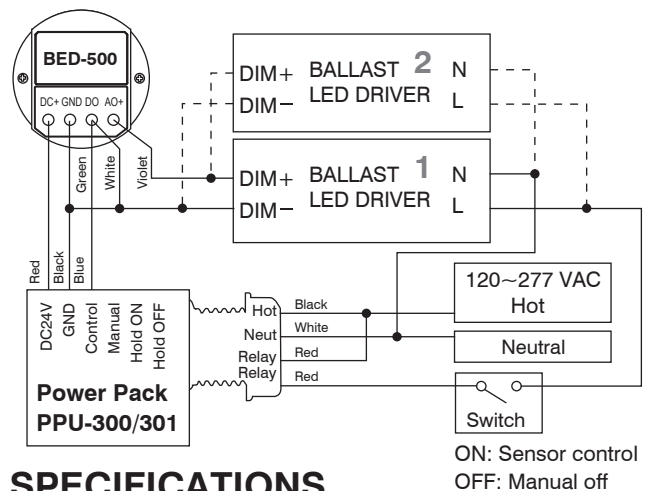

### SPECIFICATIONS

Power supply	12~24 VDC $\pm$ 5%
Photo sensor	Digital data control ambient light sensor
Current drain	15 mA typical
Digital output	Isolated dry contact, max. 1A
Dim control	0-10V, max. 25 mA sinking current
Ta & Tb for DSVM	0.5-6 Hour programmable
High dim level	SmartDIM or 50-100% StepDIM programmable
Low dim level	0-40% programmable
Sensing range	Approx. 0.2 ~ 200 fc (2~2,000 lux)
Field of view	Approx. 80°
Op. humidity	Max. 95% RH
Op. temperature	-40°F~131°F (-40°C~55°C)
Dimensions	Ø2.56" x H1.77" (Ø65 x H45mm)