

BPD-502 series

Low Voltage SmartDIM Daylight Sensor



OVERVIEW

The BPD-502 series member of the TRANS family is a low voltage daylight sensor designed for automatic daylighting control. This sensor is capable of maintaining the ambient light level within a preset range via continuous dimming the connected lights based on the daylight available in the space. For the spaces with minor daylight, the sensor can also be used to provide energy efficient automatic dimming control, thus prevents energy waste from over lighting.

This daylight sensor employs a cutting edge digital ambient light sensor (ALS) with an advanced SmartDIM control algorithm developed by IR-TEC to provide a closed loop, continuous dimming lighting control for achieving the energy efficiency required by today's sustainable buildings. When daylighting level increases/decreases, the sensor will fade down/ramp up the connected lights in a smooth way to maintain the overall ambient light level within the preset range. The sensor will open its isolated dry contact to shut off the lights if ambient light level exceeds the shut-off threshold to maximize energy saving.

Like all sensors in the TRANS family, the BPD-502 series is also available in various mounting options. This feature offers a second-to-none design and installation flexibility for daylight harvesting and control applications in sustainable buildings.

FEATURES

- Digital data control ambient light sensor
- Human-eye matching spectral response
- 12~24VDC low voltage power operation
- SmartDIM continuous dimming technology
- Available with 0-10V dimmable driver/ballast
- Isolated dry contact for high level shut-off
- Easy to set the desired ambient light level
- Sensor operation LED indicator built-in
- Available with variety of mounting options

APPLICATIONS

The BPD-502 series daylight sensor can be used in various applications to meet the requirements for daylight harvesting in areas defined as daylighting control zones.

- Educational
- Industrial/retail
- Public Buildings
- Commercial

Wiring Diagram

Basic wiring diagrams are included for general reference. Consult with an IR-TEC team member if a more complex wiring diagram is required.

• Standalone Fixture Control

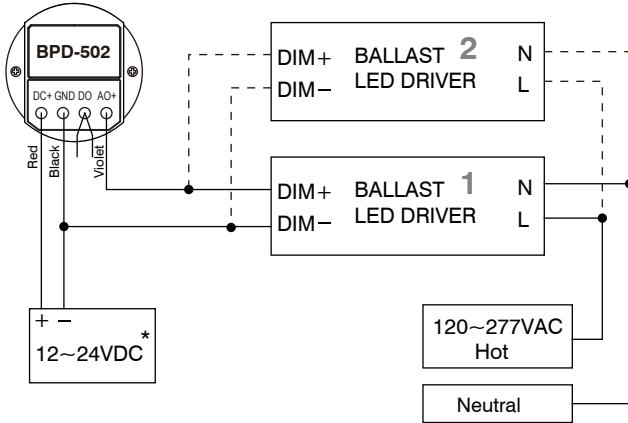

* DC power can be supplied from the driver with auxiliary DC power output or other source.

• Power Pack Control

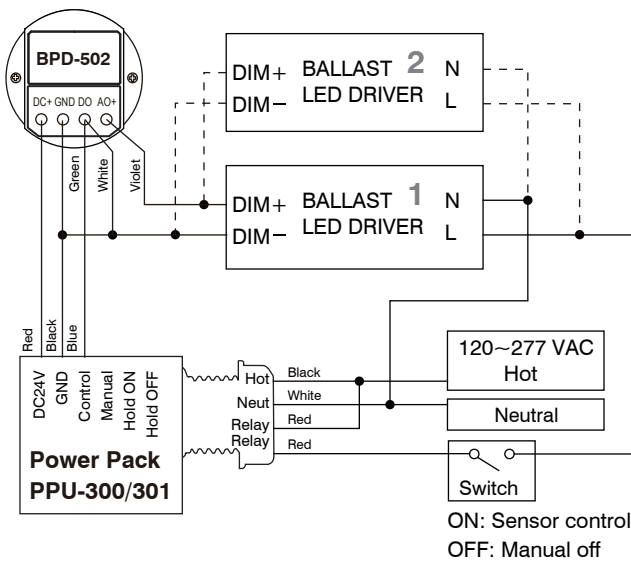

OPERATIONS

The BPD-502 series is a closed loop daylight sensor operated by 12-24VDC that provides an isolated dry contact to turn off the lights when the ambient light level exceeds the shut-off threshold, and a SmartDIM control to regulate the output of 0-10V dimmable lighting through constantly measuring the light level in the space. The sensor can be applied to control lighting in areas that receive sufficient daylight, thus the electric lights can be automatically dimmed within a preset range or switched off.

Mounting Options

The BPD-502 series can be mounted into the ceiling, attached to a fixture or mounted into a junction box to control the connected lighting. The mounting options are available by combining a specific mounting bracket from the chart below. The bracket will be shipped with the sensor when ordered with the respective code. Mounting option code F and W allow the BPD-502SX sensor to be directly integrated with OEM light fixture for indoor or wet location.

Code	Mounting Option	Mounting Bracket
F	Fixture Integrated	---
W*	Wet Location	---
E	Fixture External	EMB-500
S	Ceiling Surface	SMB-500
P*	IP-66 Fixture External	PMB-500
C	Junction Box	CMB-500
R	Ceiling Recess	RMB-500

*Available for IP-66 fixture integration

SPECIFICATIONS

Power supply	12~24 VDC ± 5%
Photo sensor	Digital data control ambient light sensor
Current drain	15 mA typical
Digital output	Isolated dry contact, max. 1A
SmartDIM output	0-10V
SmartDIM level	Manual set
Field of view	Approx. 80°
Maximum control	50 drivers/ballasts, sink current <0.5mA ea.
Mounting height	8~12 ft. (2.4~3.6m)
Op. humidity	Max. 95% RH
Op. temperature	-40°F~131°F (-40°C~55°C)
Dimensions	Ø2.56" x H1.77" (Ø65 x H45mm)