

SOLO

Energy Saving Auto-Switch

LC-730S / 730T

DETECTION PATTERN

Top View

140°, 10 x 10m (at 25°C)

Side View

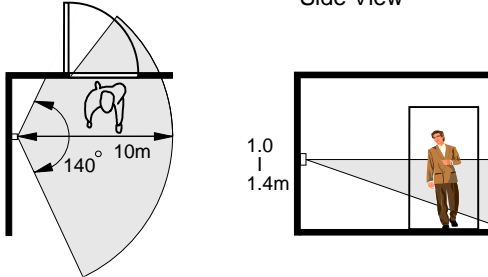

WIRING DIAGRAM

A. LC-730S single control

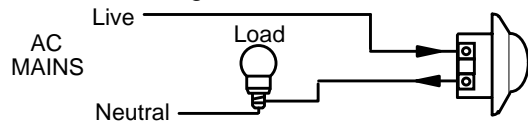

B. For heavy load or non-applicable PL lamp

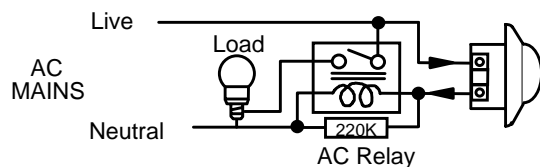

C. LC-730T Two-way parallel control

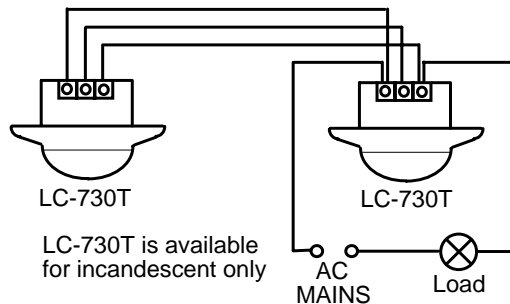

INSTALLATION

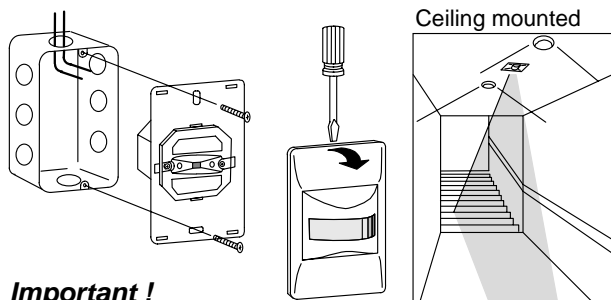

Important !

- Do not install SOLO behind the opened door, curtain or any objects may block the sensor.
- Do not place the front cover up side down. Note the "UP" mark inside the front cover.



Installation Instructions

TEST & ADJUSTMENTS

- Apply AC power and the light will be switched on about 30 seconds for SOLO to warm up.
- Walk across within the detection range, light will be switched on whenever motion is detected.
- Adjust the **TIME** and **LUX** controllers to set the desired light-on threshold and delay time.

TIME

Light-on delay time can be set from approximate 8 seconds to 6 minutes. Further detection during delay time will reset the timer.



LUX

A built-in CdS photocell determines the operation of by sensing the ambient light level.

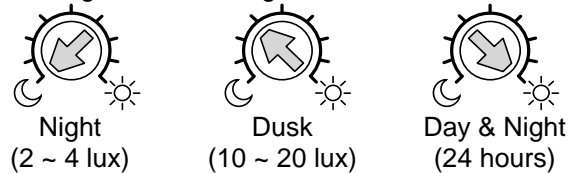

SPECIFICATIONS

Detection method	Passive Infrared (PIR)
Infrared sensor	Dual element, low noise
Power supply	120 VAC, 60 Hz
Detection range	140°, 10m at 25°C
Delay time	8 sec. ~ 6 min.
Load capacity	Max. 120V, 300W (Resistive)
Screw pitch	83.50mm
Mounting height	1.0 ~ 1.4m (3.3 ~ 4.6 ft)
Temperature	-20° ~ +50°C (-4° ~ +122°F)
Dimensions	120 x 70 x 50 mm
Unit weight	130 gram

