

IR-TEC

SUPERGUARD

Alarm Control Panel

MCP-6 series

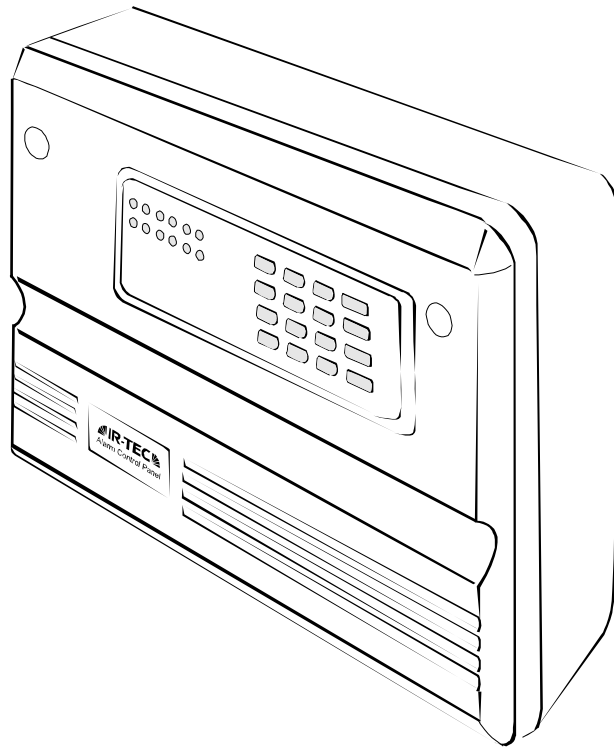

INSTALLATION & OPERATION MANUAL

To provide optimal performance of this security system, please read all contents of this manual carefully before installing and operation. Improper operation or system setting may result in inferior performance of the system.

CONTENTS

1. INTRODUCTIONS	3
2. SYSTEM CONFIGURATION.....	3
3. SYSTEM PLANNING & INSTALLATION	4
3.1 System Planning	4
3.2 System Installation.....	5
3.3 Detection Device Connections	8
4. SYSTEM DESCRIPTION	9
4.1 System Modes	9
4.2 Zone Protection Types	11
4.3 System Alarm.....	13
5. SYSTEM FUNCTIONS AND SETTINGS	16
5.1 Function Block	16
5.2 User Setting Mode	17
5.3 Installer Setting Mode (ISM)	22
5.4 System Operations	27
5.5 System Alarm Reset.....	28
5.6 Factory Default Reset.....	29
5.7 Factory Default Settings.....	29
6. TROUBLESHOOTING	30
7. SYSTEM SPECIFICATIONS.....	31

1. INTRODUCTION

Thank you for purchasing IR-TEC MCP-6 series SUPERGUARD, an independent 8-zone intruder alarm control panel designed for residential or light commercial/industrial security protection. The MCP-6 series can be operated and programmed via its on-board keypad or optional RKP-6 Remote Keypad. System owner can program 1 master code, 8 user codes and 1 service code for different system users.

In addition to 6 fully programmable intruder alarm zones, the panel also provides 24-hour anti-tamper and PA (Personal Attack) loops for total protection. Each alarm zone features with advanced “Loop-resistance Auto Detection” technology to prevent technical sabotage. In addition to its built-in siren output, MCP-6 also provides Relay, Strobe and Bell outputs for versatile applications.

MCP-6 series product family includes the following products at your choice;

- **MCP-6** : Standard type, RKP-6 compatible.
- **MCP-6RC** : RF remote controllable type, RCP-6 & RKP-6 compatible.
- **RKP-6** : Remote keypad for all MCP-6 series control panels.
- **RCP-6** : RF remote control keyfob for MCP-6RC.

2. SYSTEM CONFIGURATION

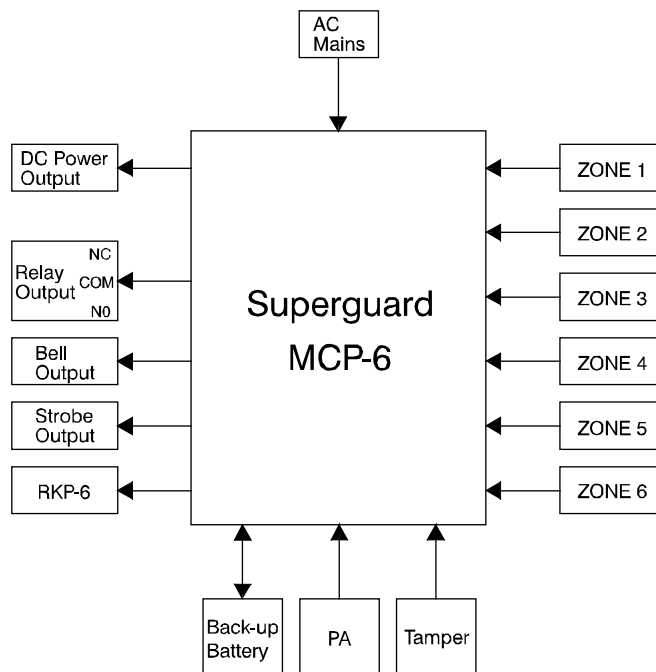

Fig. 2.1 System configuration

The MCP-6 series is directly powered by AC mains. It also provides 13.8V, 500 mA DC power for the operation of system devices (sensors, detectors). Its form C relay output can be used to activate auto-dialer or other auxiliary alarm devices. The Bell and Strobe outputs provide 12 VDC power for bell/siren or strobe to indicate the alarm condition. The MCP-6 series should connect with an adequate rechargeable battery (12 VDC, 1.2~3.2 AH) as the back-up power source while mains power failure.

PA zone should connect with NC type panic button for emergency help. TAMPER zone can loop tamper protection of all system devices to prevent the system being sabotaged. Z1 ~ Z6 are intruder alarm zones for connection with NC (factory default) or NO (require setting ADLR enabled) type of intrusion detectors. Typical system connections are shown as figure 2.2.

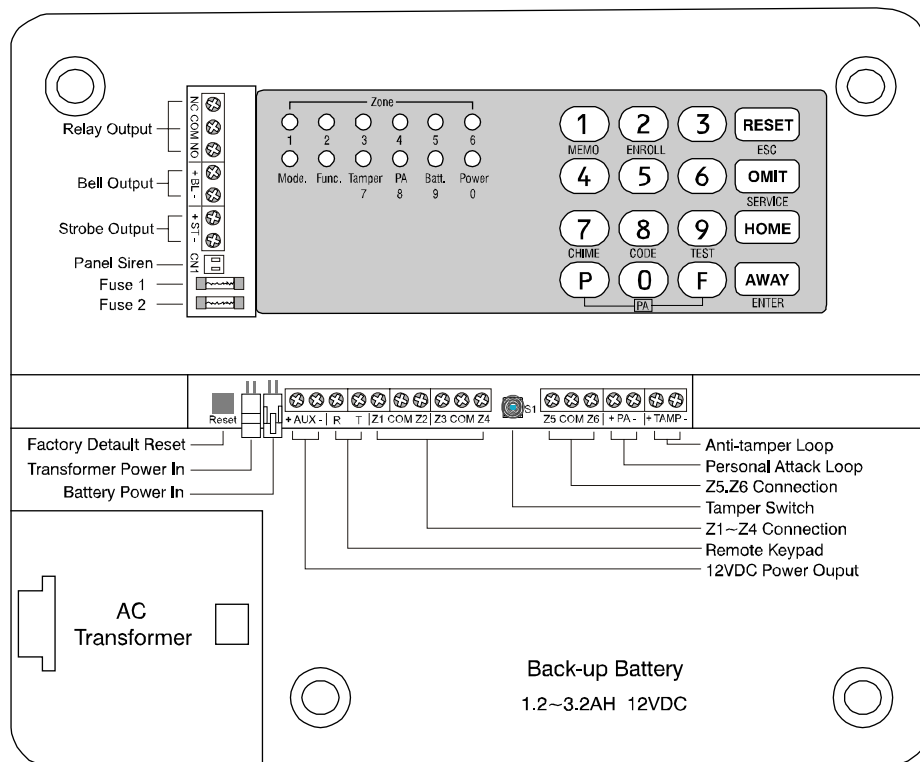

Fig. 2.2 Typical system connection

3. SYSTEM PLANNING & INSTALLATION

3.1 System Planning

Before designing or planning the system, the installer should take the followings into account while determine the required protection of every individual zone;

- Daily living pattern of system owner.
- Normal entrance and exit routes.
- Output formats of all system devices.
- Availability of AC mains power supply.

To install the MCP-6RC, please ensure that the panel is located within the radio range of RCP-6 remote control keyfob. The strength of radio transmission will be reduced by different wall material. Figure 3.1 shows various radio transmission ratios with different wall material.



Wall Material					
Transsion Ratio	Brick 60-90%	Wood 80-95%	Concrete Wall 20-60%	Metal Sheet 0-10%	Glass 70-90%

Fig. 3.1 Radio transmission ratio vs. Wall material

3.2 System Installation

In addition to the control panel, an intruder alarm system requires various devices to achieve its function. The following sections briefly describe the functions of widely used devices in today's system. For detailed application notes, please refer to the instructions of each individual device.

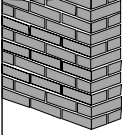
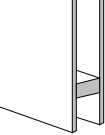
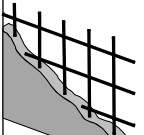
3.2.1 Motion detectors

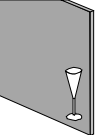
Motion detectors are generally used to detect the presence of intruders by detecting their movements. Dual Technology Motion Detectors and Passive Infrared Motion Detectors are the most widely used intruder detecting devices. These detectors utilize state-of-the-art motion sensing technologies to detect the intrusion, and then generate alarm signal to the control panel. Using only high quality motion detectors is vitally important to ensure a reliable system operation. Please refer to section 3.3 for more details about the connection between motion detectors and control panel.

3.2.2 Magnetic contact

Magnetic contact is normally used to detect open/closed status of the protected door/window. When installing magnetic contact, ensure the protected door/window can be securely closed. Please refer to section 3.3 for more details about the connection between magnetic contact and control panel.

3.2.3 Bell (siren) and Strobe

Alarm bell (siren) can be used to deter the intruder and strobe light can be used to indicate the alarm status. Connect bell (siren) and strobe as figure 3.2 shown. **BL+** and **BL-** should connect with bell (siren), **ST+** and **ST-** should connect with strobe light. Bell (siren) may be installed indoor or outdoor. Strobe light should be installed outdoors at where security personnel can directly visualize. All alarm warning devices should be installed with proper protection and wires should be concealed to avoid sabotage.

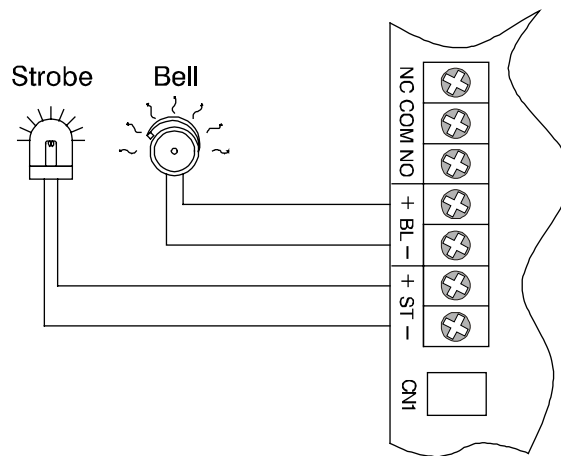

Fig. 3.2 Connection of Bell and Strobe

3.2.4 Alarm relay output

MCP-6 series also provides a form C relay contacts, which can be used to activate other optional alarm devices, such as auto-dialer, emergency lighting, video recorder...etc.

3.2.5 Panel installation point

The control panel should be installed at secured, concealed place with stable power supply and easy access for operation. If using remote control keyfob to arm/disarm the system, please ensure that the panel can reliably receive the RF signal at the installation point.

3.2.6 Remote keypad installation point

If using RKP-6 remote keypad, it should be installed at the entrance points of building. The RKP-6 is not weatherproof, do not install outdoors without proper protective enclosure.

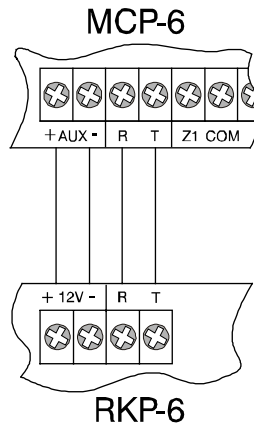

Fig. 3.3 RKP-6 connection

3.2.7 Tamper protection

Tamper loop (NC) is provided to prevent sabotage of alarm detection devices. The tamper output of all alarm detection devices should be connected in serial with “TAMP” terminals of MCP-6 series as the figure 3.4 shown.

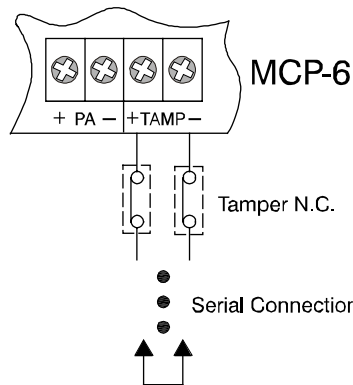

Fig. 3.4 Tamper loop connection

3.2.8 PA (Personal Attack) protection

The PA protection loop can be used to activate an alarm condition for emergency help. Figure 3.5 shows typical connection of PA protection loop.

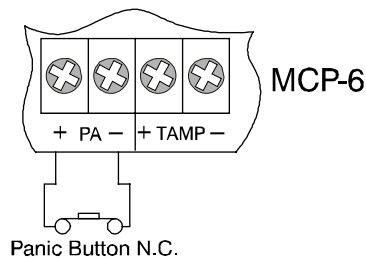

Fig. 3.5 PA protection loop connection

3.2.9 Back-up battery

It is necessary to connect a 12 V, 1.2 ~ 3.2 AH rechargeable battery as system's back-up power, while AC mains interrupts. Fig. 3.6 shows the connection of back-up battery.

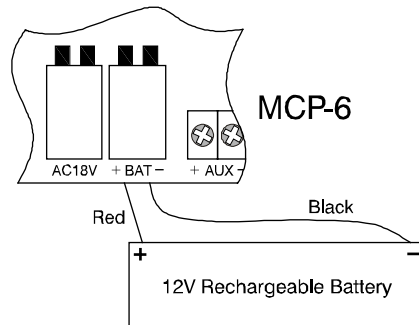

Fig. 3.6 Back-up battery connection

3.3 Detection Device Connections

It is recommended to connect one alarm detection device (sensor, detectors) to one zone. If multiple alarm detection devices are needed for a single zone, ensure to connect all NC type devices in serial, and all NO type devices in parallel. Each alarm zone can be programmed as with or without EOL (End-of-Line) resistor protection.

For EOL protection, the MCP-6 series provides advanced ADLR (Automatic Diagnosis of Loop Resistance) to prevent the alarm loop being sabotaged. The panel will memorize the standard resistance of each alarm loop and constantly monitor the loop resistance.

If the ADLR is enabled, a 1.2 ~ 7.2 K Ω resistor (4.7 K Ω recommended) should be connected with the detection device in serial. Once it detects sudden change of loop resistance, the tamper alarm condition will be generated.

3.3.1 EOL disabled, multiple NC type devices

If EOL protection is disabled and multiple NC type of devices are needed to connect in a single zone loop, please connect all devices in serial as the Fig. 3.7 shown.

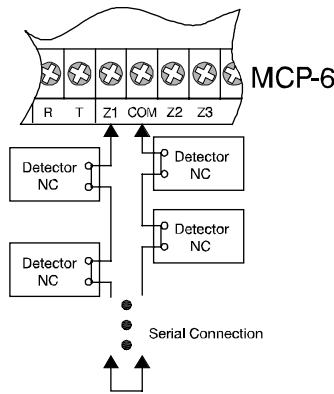

Fig. 3.7 EOL disabled, multiple NC devices

3.3.2 EOL enabled, multiple NC type devices

If EOL protection is enabled and multiple NC type of devices are needed to connect in a single zone loop, please connect all devices and an adequate EOL resistor in serial as the Fig. 3.8 shown.

Note: The factory default of ADLR is “disabled”. To enable the ADLR, installer should enter into “Installer Setting Mode” to activate the ADLR.

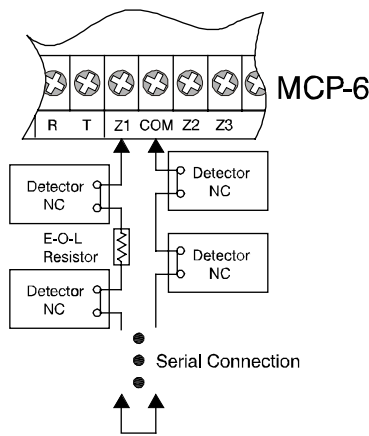

Fig. 3.8 EOL enabled, multiple NC devices

4. SYSTEM DESCRIPTION

4.1 System Modes

The MCP-6 series provides 4 protection modes (DISARM, AWAY, HOME, SERVICE) and 2 setting modes (USER, INSTALLER) for user operation. Details of various protection modes are described in section 4.2 and details of setting modes are described in section 5.

4.1.1 DISARM

The “DISARM” mode means that the control panel is “resting”. Only Tamper and PA loops remains active.

Note: The “Mode” LED will light ON at DISARM mode.

4.1.2 AWAY

The “AWAY” mode means that the control panel is “armed”. If any system device detects intruder, the system will respond with alarm condition.

Note: The “Mode” LED will be OFF at AWAY mode.

4.1.3 HOME

The “HOME” mode means the protection mode while people staying in the protected building.

Note: The “Mode” LED will slow blink (1 blink per second) at HOME mode.

4.1.4 SERVICE

The “SERVICE” mode is designed for facility management service staff while system user is not in the premises. This is actually a partial armed protection mode. For example, system user can set this mode to allow cleaner to enter the designated areas, but not the restricted areas.

Note: The “Mode” LED will fast blink (3 blinks per second) at SERVICE mode.

4.1.5 User Setting Mode

The User Setting Mode (USM) allows system user to program the followings;

- Setting/changing the Master code.
- Setting/changing the User codes, Service code.
- Enroll RCP-6 remote control keyfob. (For MCP-6RC)

Note: The “Func.” LED will light ON under USM.

4.1.6 Installer Setting Mode

The Installer Setting Mode (ISM) allows system installer to program all system settings. Only professional installer is allowed to operate under this mode,

improper setting may result in system malfunction or protection failure.

Note: The “Func.” LED will quick-blink under ISM.

4.1.7 Power indication

The “Power” LED indicates power supply status of the system. The system may not have normal operation with unstable power supply.

- Power LED : ON → means power supply is normal.
- Power LED : Blink → means abnormal power supply.
- Power LED : OFF → means power supply failure.

4.1.8 Back-up battery indication

The “Batt.” LED indicates the status of back-up battery. The system will automatically charge the battery whenever the voltage is low.

- Batt. LED : ON → means the battery is normal.
- Batt. LED : Blink → means battery low or under charging.
- Batt. LED : OFF → means battery is dead, please replace with new one.

4.2 Zone Protection Types

The MCP-6 series provides various zone protection types with different responses. Factory default settings shall meet general requirements. If not, installer can program specific settings as required.

There are 4 protection types for each alarm zone, including **Delay**, **Walk-through**, **Instant** and **Omit**. Each offers different responses while triggering under different protection modes (DISARM, AWAY, HOME, SERVICE).

DISARM

Zone type	System response while triggering
Delay	1. Triggered zone LED lights ON. 2. If “Chime” function is enabled, the buzzer of control panel will “chirp” as set time.
Walk-thru	Triggered zone LED lights ON.
Instant	Triggered zone LED lights ON.
Omit	Triggered zone LED lights ON.

PA	<ol style="list-style-type: none"> 1. Full alarm* 2. Triggered zone LED lights ON.
Tamper	<ol style="list-style-type: none"> 1. Panel warning** 2. Triggered zone lights ON.

* Full alarm means all connected alarm output devices (strobe, siren...) will be activated.

** Panel warning means only the buzzer built-in the panel will sound.

AWAY

Zone type	System response while triggering		
	Within exit delay	Armed status	Within entry delay
Delay	<ul style="list-style-type: none"> ● Delay timer pauses until trigger stops. ● Triggered zone LED lights ON 	<ul style="list-style-type: none"> ● Enter entry delay and timer starts countdown. ● Triggered zone LED lights ON 	<ul style="list-style-type: none"> ● Disarm the system before time expires, or full alarm goes off. ● Triggered zone LED lights ON
Walk-thru	<ul style="list-style-type: none"> ● Triggered zone LED lights ON 	<ul style="list-style-type: none"> ● Full alarm 	<ul style="list-style-type: none"> ● Triggered zone LED lights ON
Instant	<ul style="list-style-type: none"> ● Full alarm ● Triggered zone LED lights ON 	<ul style="list-style-type: none"> ● Full alarm ● Triggered zone LED lights ON 	<ul style="list-style-type: none"> ● Full alarm ● Triggered zone LED lights ON
Omit	<ul style="list-style-type: none"> ● Triggered zone LED lights ON 	<ul style="list-style-type: none"> ● Triggered zone LED lights ON 	<ul style="list-style-type: none"> ● Triggered zone LED lights ON
PA	<ul style="list-style-type: none"> ● Full alarm ● Triggered zone LED lights ON 	<ul style="list-style-type: none"> ● Full alarm ● Triggered zone LED lights ON 	<ul style="list-style-type: none"> ● Full alarm ● Triggered zone LED lights ON
Tamper	<ul style="list-style-type: none"> ● Full alarm ● Triggered zone LED lights ON 	<ul style="list-style-type: none"> ● Full alarm ● Triggered zone LED lights ON 	<ul style="list-style-type: none"> ● Full alarm ● Triggered zone LED lights ON

HOME

Zone type	System response while triggering		
	Within exit delay	Armed status	Within entry delay
Delay	<ul style="list-style-type: none"> ● Delay timer pauses until trigger stops. ● Triggered zone LED lights ON. 	<ul style="list-style-type: none"> ● Enter entry delay and timer starts countdown. ● Triggered zone LED lights ON 	<ul style="list-style-type: none"> ● Disarm the system before time expires, or alarm goes off. ● Triggered zone LED lights ON

Walk-thru	<ul style="list-style-type: none"> ● Triggered zone LED lights ON 	<ul style="list-style-type: none"> ● Triggered zone LED lights ON 	<ul style="list-style-type: none"> ● Triggered zone LED lights ON
Instant	<ul style="list-style-type: none"> ● Panel warning ● Triggered zone LED lights ON. 	<ul style="list-style-type: none"> ● Panel warning ● Triggered zone LED lights ON. 	<ul style="list-style-type: none"> ● Panel warning ● Triggered zone LED lights ON.
Omit	<ul style="list-style-type: none"> ● Triggered zone LED lights ON 	<ul style="list-style-type: none"> ● Triggered zone LED lights ON 	<ul style="list-style-type: none"> ● Triggered zone LED lights ON
PA	<ul style="list-style-type: none"> ● Full alarm ● Triggered zone LED lights ON 	<ul style="list-style-type: none"> ● Full alarm ● Triggered zone LED lights ON 	<ul style="list-style-type: none"> ● Full alarm ● Triggered zone LED lights ON
Tamper	<ul style="list-style-type: none"> ● Panel warning ● Triggered zone LED lights ON 	<ul style="list-style-type: none"> ● Panel warning ● Triggered zone LED lights ON 	<ul style="list-style-type: none"> ● Panel warning ● Triggered zone LED lights ON

SERVICE

Zone type	System response while triggering
Delay	Built-in siren “chirp” once per second. Panel warning will be generated if intruder stays longer than 30 seconds.
Walk-thru	Triggered zone LED lights ON
Instant	<ol style="list-style-type: none"> 1. Panel warning 2. Triggered zone LED lights ON
Omit	Triggered zone LED lights ON
PA	<ol style="list-style-type: none"> 1. Full alarm 2. Triggered zone LED lights ON
Tamper	<ol style="list-style-type: none"> 1. Full alarm 2. Triggered zone LED lights ON

4.3 System Alarm

4.3.1 Full alarm

The MCP-6 series provides 3 alarm outputs (relay, bell, strobe) together with built-in siren and buzzer. When full alarm goes off, all alarm outputs will be activated, except for those are set “disabled”.

- **Strobe output:** The strobe output will be constantly active when full alarm goes off. This output can only be deactivated after the system is disarmed and **RESET** key is pressed.

- **Bell output:** The bell output will be generated when full alarm goes off. It will stop as the set alarm time expired.
- **Relay output:** The relay output will be active when full alarm goes off. It will stop as the set alarm time expired.
- **Built-in siren:** The built-in siren will sound as the alarm time set when full alarm goes off.
- **Built-in buzzer:** The main function of buzzer is to provide audible indication of key operation and function setting. It will also sound as the alarm time set when full alarm goes off.

4.3.2 Panel warning

Panel warning is to alert system user about the malfunction or abnormal situation. Only the built-in siren will sound when panel warning goes off.

4.3.3 Alarm outputs under various protection modes

The following tables show alarm outputs under various protection modes;

DISARM

Zone trigger \ Output	Alarm	Tamper	PA
Strobe			✓
Bell			✓
Relay			✓
Built-in siren		✓	✓
Buzzer	*		✓

* Only active if the "Chime" function is enabled.

AWAY

Zone trigger \ Output	Alarm	Tamper	PA
Strobe	✓	✓	✓
Bell	✓	✓	✓
Relay	✓	✓	✓
Built-in siren	✓	✓	✓
Buzzer	✓	✓	✓

HOME

Zone trigger Output	Alarm	Tamper	PA
Strobe			✓
Bell			✓
Relay			✓
Built-in siren	✓	✓	✓
Buzzer			✓

SERVICE

Zone trigger Output	Alarm	Tamper	PA
Strobe		✓	✓
Bell		✓	✓
Relay		✓	✓
Built-in siren	*	✓	✓
Buzzer		✓	✓

* Siren “chirp” once per second until intruder leaves within 30 seconds, or siren will sound. If alarm zone is set as “instant” zone, the built-in siren will go off immediately.

5. SYSTEM FUNCTIONS AND SETTINGS

5.1 Function Block

Figure 5.1 shows the function block of system operations and functions.

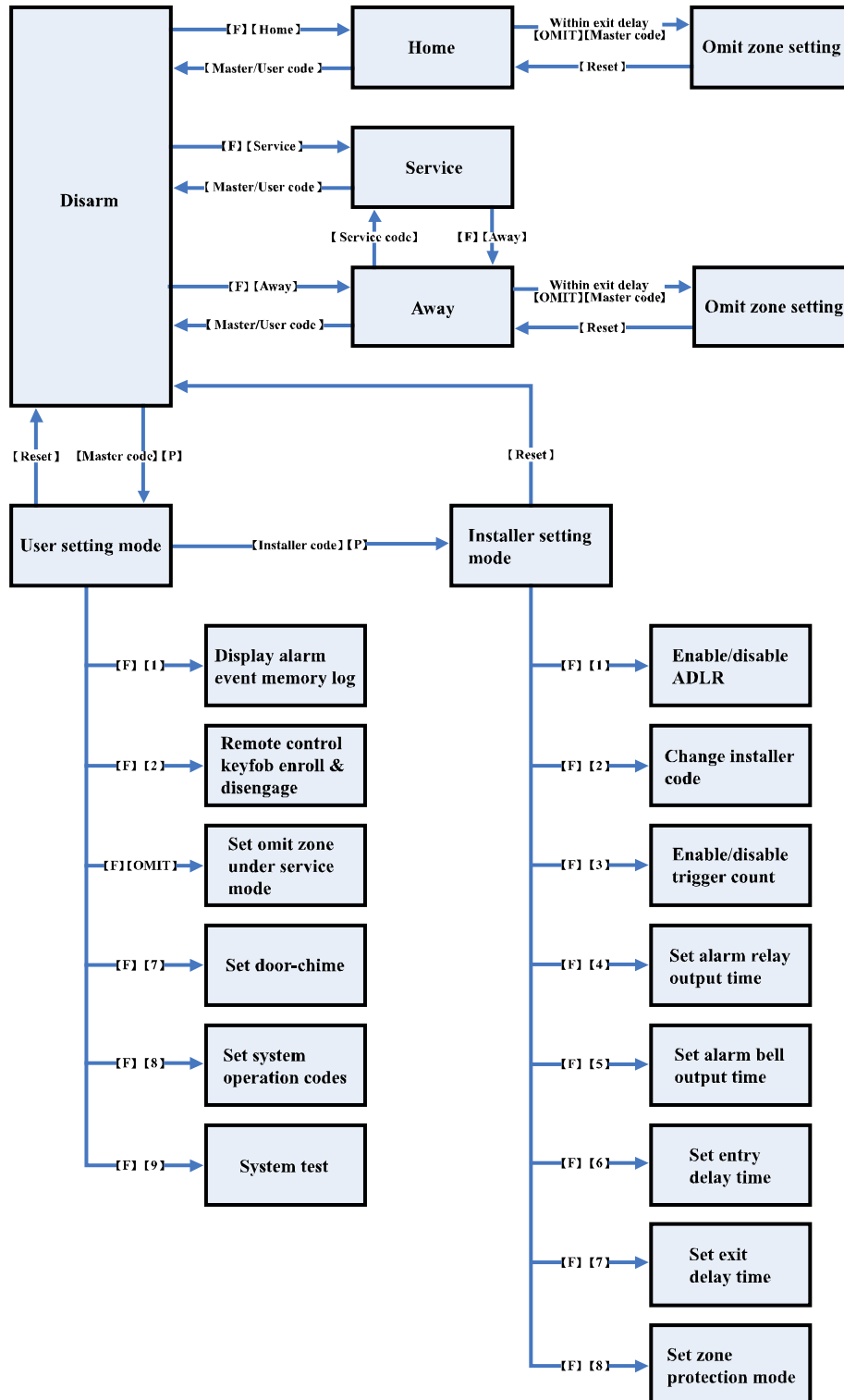

Fig. 5.1 System function block diagram

5.2 User Setting Mode

To access into User Setting Mode (USM), enter “**Master Code**” under DISARM mode and press **P** key. USM allows user to do the following operations;

- Display the alarm event memory.
- Enroll the Remote Control Keyfob for MCP-6RC.
- Set the operation codes, including Master Code, User Codes, Service code
- Set the open zones under “SERVICE” mode.
- Enable/disable “chime” function.
- Execute system test.
- Access into the Installer Setting Mode.

Note: The system will return to DISARM mode if there is no any key operation within 30 seconds.

5.2.1 Alarm event memory display

The panel will memorize the system protection mode and triggered zone of the previous 32 alarm events. System user or manager can recall the alarm event memory in accordance with the procedure as table 5.1 shown. Table 5.2 shows the definition of various panel LED indications.

Table 5.1 Alarm event memory display

No.	Operation	LED indication	Remark
1	Enter “ Master Code ” under DISARM mode, press P and panel will output a long “beep”.	Mode LED → ON Func. LED → ON	Entering USM
2	Press F & 1 buttons. Panel will output a long “beep”.	Display the latest alarm event.	Refer to table 5.2
3	Press 1 again to display the previous event.	Display the previous alarm event.	Total 32 events
4	After pressing 1 for 32 times, the system will return to DISARM. Panel will output a long “beep”.	Mode LED → ON Func. LED → OFF	
Note: Press RESET (ESC) button to return DISARM mode.			

Table 5.2 Definitions of alarm event LED indications

LED	Definition	Status	Meaning
Mode	Status when alarm occurred	ON	DISARM
		Slow blink	HOME
		Fast blink	SERVICE
		OFF	AWAY
1~6	Zone 1 ~ 6	ON	The triggered zone
PA	Personal Attack		
Tamp	Tamper		

5.2.2 Remote Control Keyfob enrollment (for MCP-6RC only)

The MCP-6RC can be armed/disarmed by using up to 10 enrolled Remote Control Keyfob. Please refer to the table 5.3 for enrollment and discharge.

Table 5.3 Enroll/disengage the Remote Control Keyfob

Step	Operation		LED indication	Remark
1	Enter “ Master Code ” under DISARM mode, press P and panel will output a long “beep”.		Mode LED → ON Func. LED → ON	Entering USM
2	Press F & 2 buttons. Panel will output a long “beep”.		Mode LED → Blink Func. LED → ON LED 1,2...9,0 → ON means enrolled. OFF means non-enrolled.	
3	Press the available key 0 ~ 9		The respective LED will flash to indicate waiting for enrollment.	
4	Enroll	<ol style="list-style-type: none"> 1. Press  on the keyfob. 2. When panel receives the signal, it will output a long “beep” to confirm and return to step 3. 	Follow as step 2	

	Disengage	Press AWAY key on the panel and it will output a long “beep” to confirm, then return to step 3.		
5	After completion, press RESET key to return to DISARM mode.	Mode LED → ON Func. LED → OFF		
<p>Note 1: To return to DISARM mode at anytime, you may press RESET key and panel will output a long “beep”.</p> <p>Note 2: System manager or owner should establish system management database (incl. zone information, user name, passwords...).</p>				

5.2.3 OMIT Zone setting under Service mode

Zone omitting may be used when detector is found faulty or user wants to temporarily open specific zone(s) for special purpose. For detailed operation instruction about zone omitting, please refer to section 5.4. There can be different zone omitting settings under different protection modes (AWAY, HOME, SERVICE). This section is ONLY for zone omitting under Service mode.

Table 5.4 Zone omit under Service mode

Step	Operation	LED indication	Remark
1	Enter “ Master Code ” under DISARM mode, press P and panel will output a long “beep”.	Mode LED → ON Func. LED → ON	Entering USM
2	Press F and OMIT keys. Panel output a long “beep”.	Mode LED → Blink Func. LED → ON LED 1~LED 6 → ON means zone omitted	
3	1. Press the zone number to be omitted. Ex. 1 means zone 1. 2. To disengage the omitted zone, press the zone number again.	As step 2.	
4	press RESET key to return to DISARM mode.	Mode LED → ON Func. LED → OFF	
<p>To return to DISARM mode at anytime, you may press RESET key and panel will output a long “beep”.</p>			

5.2.4 Chime Function

Under DISARM mode, “Chime” function can be enabled to alert the user with short “beep” that somebody is entering the premises.

Note: Chime function is only available with the DELAY zone under DISARM mode.

Table 5.5 Chime function setting

Step	Operation	LED indication	Remark
1	Enter “ Master Code ” under DISARM mode, press P and panel will output a long “beep”.	Mode LED → ON Func. LED → ON	Entering USM
2	Press F and 7 and panel will output a long “beep”.	Mode LED → Blink Func. LED → ON	
3	1. Set the chime time (in second) by pressing 1 ~ 9 . 2. To disable chime, press 0 . 3. System will return to DISARM mode after setting completed.	Mode LED → ON Func. LED → OFF	
To return to DISARM mode at anytime, you may press RESET key and panel will output a long “beep”.			

5.2.5 Code setting

The system operation code (password) is a 4-digit number that can be used to operate the system. Different user can use different code for different operation.

- Master Code → Entering USM, Changing code (Master, User and Service), Arm/disarm the system.
- User Code → Arm/disarm the system.
- Service Code → Arm the system, Entering into Service mode.

Table 5.6 Setting the code

Step	Operation	LED indication	Remark
1	Enter “ Master Code ” under DISARM mode, press P and panel will output a long “beep”.	Mode LED → ON Func. LED → ON	Entering USM
2	Press F and 8 and panel will output a long “beep”.	Mode LED → Blink Func. LED → ON LED 1 → ON	

		LED 0, 2 ~ 9 → ON means code set, OFF means no code set.	
3	1. To set Master Code, press 1 . 2. To set/disengage User Code 2~9, press 2 ~ 9 . 3. To set/disengage Service Code, Press 0 .	The LED of setting code will quick-blink (3 blinks per second)	Master Code cannot be disengaged.
4	Set Enter new code XXXX .	Same as step 3	All codes have to be 4-digit.
	Disengage Enter 0000 to disengage		
5	Press AWAY to store the setting code and return to step 3.	Same as step 2	
6	After completing the setting, press RESET to return to DISARM mode.	Mode LED → ON Func. LED → OFF	
To return to DISARM mode at anytime, you may press RESET key and panel will output a long “beep”.			

5.2.6 System test

To conduct system test after installing the system, please follow the instructions stated as table 5.7.

Table 5.7 System test procedures

Step	Operation	LED indication	Remark
1	Enter “ Master Code ” under DISARM mode, press P and panel will output a long “beep”.	Mode LED → ON Func. LED → ON	Entering USM
2	Press F and 9 and panel will output a long “beep”.	Mode LED → Blink Func. LED	Entering system test mode
3	Relay output test → press 1	LED 9 → ON means relay output normal.	Press the same key to stop output.
	Strobe output test → press 2	LED 0 → ON means strobe output normal.	
	Bell output test → press 3	Buzzer will sound to indicate bell output	
	Built-in siren test → press 4	Built-in siren sound	
4	Zone 1~6 trigger test	LED1~6 lights on	Built-in siren sounds
	PA trigger test	LED PA lights on	
	Tamper trigger test	LED Tamp light on	

5	After test completed, press RESET to return to DISARM mode.	Mode LED → ON Func. LED → OFF	
The system will automatically return to DISARM mode if lack of any trigger signal or keypad operation within 30 seconds during system test mode.			

5.2.7 Enter / Exit Installer Setting Mode

The Installer Setting Mode (ISM) is for professional installer only. For general users who are not familiar with detailed system operation, please do not attempt to operate within ISM to avoid system malfunction. To enter/exit ISM, please refer to the table 5.8. For detailed description of ISM, please refer to section 5.3 Installer Setting Mode.

Table 5.8 Enter/Exit Installer Setting Mode

Step	Operation	LED indication	Remark
1	Enter " Master Code " under DISARM mode, press P and panel will output a long "beep".	Mode LED → ON Func. LED → ON	Entering USM
2	Enter " Installer Code " under USM, press P and panel will output a long "beep".	Mode LED → ON Func. LED → Fast blink	Entering ISM
3	To exit from ISM and return to DISARM mode, press RESET	Mode LED → ON Func. LED → OFF	Exiting ISM
Note: If new installer code is set, please ensure to record the new code.			

5.3 Installer Setting Mode (ISM)

The installer can proceed more system function settings under ISM mode, including Automatic Diagnosis of Loop Resistance (ADLR), Trigger Count setting, Relay output time setting, Bell output time setting, Entry delay time setting, Exit delay time setting, Zone protection mode setting, Changing the Installer Code...etc. To proceed the following settings, installer should enter into ISM by following the procedures stated as section 5.2.7.

5.3.1 Enable / Disable ADLR

The ADLR is designed to prevent detection loop failure due to purposely sabotage. A 4.7 Kohm EOL (End-of-Line) resistor can be connected in serial to provide ADLR protection. The ADLR protection can be enabled/disabled by the following procedures.

Table 5.9 Enable/disable ADLR

Step	Operation	LED indication	Remark
1	Under ISM, press F and 1 , panel will output a long “beep”.	Mode LED→ OFF Func. LED→ Fast blink LED 1~LED 6 will light on to indicate if ADLR is enabled.	Entering into ADLR setup
2	Press ADLR zone 1 ~ 6 to enable or disable.	As step 1 shown	
3	Press AWAY key to restore the setting and return to ISM. Panel will output a long “beep”.	Mode LED→ ON Func. LED→ Fast blink	Note 1
<p>Note 1: While setting ADLR, all detectors should not be triggered in order to measure normal loop resistance value.</p> <p>Note 2: To exit from ISM at any time, press RESET and panel will output a long “beep” to confirm.</p>			

5.3.2 Change the Installer Code

Please refer to table 5.10 to change the Installer Code. Ensure to record the new code and file it properly for future need.

Table 5.10 Changing the Installer Code

Step	Operation	LED indication	Remark
1	Under ISM, press F and 2 , panel will output a long “beep”.	Mode LED→ OFF Func. LED→ Fast blink	Entering into Installer Code setup.
2	Input the new code X X X X	Mode LED→ OFF Func. LED→ Fast blink	Must be 4 digits
3	Press AWAY key to restore the setting and return to ISM. Panel will output a long “beep”.	Mode LED→ ON Func. LED→ Fast blink	
<p>If any wrong key or wrong code input, press RESET to cancel the setting and return to the ISM.</p>			

5.3.3 Trigger Count setting

The “Trigger Count” is designed to reduce the possibility of false alarm caused by unstable detector in harsh environment. If “Trigger Count” is enabled, the system will not response with alarm condition when it receives

the first alarm signal. The alarm condition will be generated only if the system receives second alarm signal within a period of time. To set the “Trigger Count” function, please refer to table 5.11.

Note: The Trigger Count function is only available on “instant” zones.

Table 5.11 Trigger Count enabled/disabled

Step	Operation	LED indication	Remark
1	Under ISM, press F and 3 , panel will output a long “beep”.	Mode LED→OFF Func. LED→Fast blink LED 1~LED 6 will light on to indicate the trigger count enabled zones ◦	Entering trigger count setup
2	Press the zone number to be set as “Trigger Count” enabled.	Same as step 1	Press to enable and disable
3	Press AWAY key to restore the setting and return to ISM. Panel will output a long “beep”.	Mode LED→ON Func. LED→OFF	
If any wrong key operation, press RESET to stop setting and return to the ISM.			

5.3.4 Relay output time setting

The relay output time can be set as required.

Table 5.12 Set relay output time

Step	Operation	LED indication	Remark
1	Under ISM, press F and 4 , panel will output a long “beep”.	Mode LED→OFF Func. LED→Fast blink	Entering into relay output time setup.
2	1. Input desired time X X X , unit in second. <ul style="list-style-type: none"> ● 0 0 0 → relay output inhibited ● 9 9 9 → constant output until alarm condition stop. 2. System will output a long beep and return to ISM after input.	Mode LED→ON Func. LED→OFF	Ex. To set relay output time for 10 seconds, enter 0 1 0
Press RESET key to return ISM at anytime you want to stop setting.			

5.3.5 Bell output time setting

Bell (siren) output is one of the most effective means to deter the intruder. However, excessive bell output may also affect the neighborhood. Setting a

proper bell output time in accordance with the actual need by following the table 5.13.

Table 5.13 Set bell output time

Step	Operation	LED indication	Remark
1	Under ISM, press F and 5 , panel will output a long “beep”.	Mode LED→OFF Func. LED→Fast blink	Entering into bell output time setup.
2	1. Input X X , unit in minute. <ul style="list-style-type: none"> ● 0 0 → Bell output inhibited ● 9 9 → Bell output 99 minutes 2. System will output a long beep and return to ISM after input.	Mode LED→ON Func. LED→OFF	Ex. To set bell output time for 2 minutes, enter 0 2 .
Press RESET key to return ISM at anytime you want to stop setting.			

5.3.6 Entry delay time setting

Entry delay time is the time given by system to allow user to disarm the system after entering the premises. Different delay time may be required for different panel location and environment. To change the entry delay time, please follow the instructions as table 5.14 stated.

Table 5.14 Change entry delay time

Step	Operation	LED indication	Remark
1	Under ISM, press F and 6 , panel will output a long “beep”.	Mode LED→OFF Func. LED→Fast blink	Entering into entry delay time setup.
2	1. Input desired time X X X , unit in second. <ul style="list-style-type: none"> ● 0 0 0 → no entry delay 2. System will output a long beep and return to ISM after input.	Mode LED→ON Func. LED→OFF	To set entry delay time for 30 sec., enter 0 3 0
Press RESET key to return ISM at anytime you want to stop setting.			

5.3.7 Exit delay time setting

The exit delay time is the time given by system to allow user to leave the premises. Different delay time may be required for different panel location and environment. To change the exit delay time, please follow the instructions as table 5.15 stated.

Table 5.15 Change Exit Delay Time

Step	Operation	LED indication	Remark
1	Under ISM, press F and 7 , panel will output a long “beep”.	Mode LED→OFF Func. LED→Fast blink	Entering into exit delay time setup.
2	3. Input desired time X X X , unit in second. ● 000 → no entry delay 4. System will output a long beep and return to ISM after input.	Mode LED→ON Func. LED→OFF	To set exit delay time for 30 sec., enter 030
Press RESET key to return ISM at anytime you want to stop setting.			

5.3.8 Zone protection mode setting

Different zone protection types under various system protection modes can be set in according with the table 5.16 stated.

Table 5.16 Zone protection type setting

Step	Operation	LED indication	Remark
1	Under ISM, press F and 8 , panel will output a long “beep”.	Mode LED→OFF Func. LED→Fast blink	Entering into zone protection type setup.
2	Select the system mode to change zone protection type. ● DISARM → Press 7 ● SERVICE → Press 8 ● HOME → Press 9 ● AWAY → Press 0	DISARM : LED 7 ON SERVICE : LED 8 ON HOME : LED 9 ON AWAY : LED 0 ON	LED 7, 8, 9 or 0 will light on to indicate the selected status.
3	1. Press 1 ~ 6 to select protection type of changing zone. 2. Press the zone key again and again to change the protection type in the sequence of “ Delay ” → “ Walk Through ” → “ Instant ” → “ Omit ”.	Zone LED indications; Delay → Slow blink Walk Thru → Fast blink Instant → ON Omit → OFF	
4	Press AWAY key to restore the zone protection type setting and return to ISM. Panel will output a long “beep”.	Mode LED→ON Func. LED→OFF	
Press RESET key to exit from Zone Protection Type setup and return to ISM.			

5.4 System Operations

5.4.1 System protection mode operations

User can operate the system for different protection modes as table 5.17 stated.

Table 5.17 System protection mode operation

Current mode	Keypad operation	Mode after operation	LED indication	
DISARM	F + AWAY ----- (Master Code) + AWAY ----- (User Code) + AWAY	AWAY	Mode LED → OFF	
	F + HOME ----- (Master Code) + HOME ----- (User Code) + HOME	HOME	Mode LED → Slow blink	
	F + CLEANER	SERVICE	Mode LED → Fast blink	
	SERVICE	F + AWAY ----- (Service Code) + AWAY	AWAY	Mode LED → OFF
		(Master Code) ----- (User Code)	DISARM	Mode LED → ON
		(Master Code) ----- (User Code)	DISARM	Mode LED → ON
HOME	OMIT + (Master Code) within exit delay time	HOME mode with zone omitted	Mode LED → Slow blink (1 blink per second) Func. LED → Fast blink (3 blinks per second)	
	(Master Code) ----- (User Code)	DISARM	Mode LED → ON	
AWAY	(Service Code)	SERVICE	Mode LED → Fast blink	
	OMIT + (Master Code) within exit delay time	AWAY mode with zone omitted	Mode LED → Fast blink Func. LED → Fast blink (3 blinks per second)	
	(Master Code) ----- (User Code)	DISARM	Mode LED → ON	

5.4.2 Set temporary omit zone

This section describes how to set the temporary omit zone under AWAY and HOME modes. Temporary zone omitting can be used under the following circumstances;

- The detector of certain zone is found faulty, unstable or tampered.
- Special condition that requires some zones to be open.

Table 5.18 Temporary omit zone setting

Step	Operation	LED indication	Remark
1	Press OMIT and input “ Master Code ” before exit delay time expires. The buzzer continues to sound.	Func. LED → Fast blink LED 1 ~ LED 6 indicate the current zone omit status. ON means zone omitted. OFF means engaged.	Ready for zone omit setting
2	Press the zone number to be omitted or engaged.	Same as step 1.	
3	Press AWAY as setting completed and return to exit delay time.	Mode LED → ON Func. LED → OFF	
To return to exit delay while setting, press RESET at anytime.			

5.5 System Alarm Reset

User must input correct “**Master Code**”, “**User Code**” or press the “**Disarm**” button of the remote control keyfob to stop the alarm condition. User should check the alarm zone display on the panel and press **RESET** button to formally reset the system alarm.

Note: If system has not been reset after an alarm event, it cannot be armed next time. Please follow the table 5.19 to properly reset the system alarm.

Table 5.19 System alarm reset

Current status	Operation	Status after operation	LED indication
Panel warning or full alarm	Input “ Master Code ” or “ User Code ”	Alarm condition is stopped	Triggered zone LED lights on.
Alarm condition stopped	Press RESET to reset the alarm condition	System alarm reset	Mode LED → ON

5.6 Factory Default Reset

Factory Default Reset may be necessary if system is unstable or breakdown due to improper operation or other reason. Factory Default Reset can restore the factory default settings of the panel, so that user can setup the whole system operation again. To reset the factory default, please follow the instructions as table 5.20.

Table 5.20 Factory default reset

Operation	System status	LED indication
1. Open the front cover of panel. 2. Remove the AC18V and +BAT- connectors	Power off	All OFF
3. Use a blade-type screwdriver to short the contacts (reset) on the PCB. 4. Remain contacts shorted and restore AC18V power connector.	Buzzer sounds	Random blink
5. Remove AC18V power connector again.	Power off	All OFF
6. Restore AC18V and +BAT- power supply. 7. Replace the front cover.	Factory default reset completed	Mode LED → ON

5.7 Factory Default Settings

5.7.1 Code default

Master Code..... 1234
 User Code Unset
 Service Code..... Unset
 Installer Code 9999

5.7.2 Zone protection type default

Zone Mode	1	2	3	4	5	6
DISARM	Omit	Omit	Omit	Omit	Omit	Omit
SERVICE	Omit	Omit	Omit	Instant	Omit	Instant
HOME	Delay	Omit	Omit	Omit	Instant	Instant
AWAY	Delay	Walk-thru	Instant	Instant	Instant	Instant

5.7.3 Other factory default

- Exit Delay Time30 Sec.
- Entry Delay Time.....30 Sec.
- Bell Output Time10 min.
- Relay Output Time2 min.
- Temporary Omit ZoneNone
- Automatic Diagnosis of Loop ResistanceDisabled
- Trigger Count FunctionDisabled

6. TROUBLESHOOTING

Many system malfunctions and failure are caused by improper operation. Please keep this manual handy for future reference after system installed. The following table highlights possible causes and remedy of some common problems. If problem still exists, please call the original installer for assistance.

No.	Status	Possible causes	Remedy
1	Power LED blinking or off.	Insufficient power supply voltage or no power.	Check power supply.
2	System cannot be armed.	<ol style="list-style-type: none"> 1. Poor power supply. 2. Invalid code input. 3. Un-enrolled remote control keyfob. 4. No reset after previous alarm. 5. Detector is faulty. 6. Door/window open. 7. Unknown reason. 	<ol style="list-style-type: none"> 1. Check power supply. 2. Input correct code. 3. Enroll the remote control keyfob. 4. Press RESET and then arm again. 5. Zone omit or call service 6. Check all door/window. 7. Call for service.
3	Zone failure	<ol style="list-style-type: none"> 1. Zone is omitted. 2. Improper loop wiring. 3. Detector is faulty. 	<ol style="list-style-type: none"> 1. Re-engage the zone. 2. Check the loop wiring. 3. Replace the detector.
4	ADLR failure	<ol style="list-style-type: none"> 1. Lack of EOL resistor. 2. ADLR function is disabled. 	<ol style="list-style-type: none"> 1. Connect EOL resistor. 2. Enable the ADLR function.
5	No power for system detecting devices.	Blown fuse or no fuse.	Replace fuse.

6	No back-up power.	Dead battery or no battery.	Replace new battery.
7	No operation beep	Microprocessor failure.	Reset factory default.
8	Poor RF receiving	1. Improper installing site 2. RCP-6 low battery.	1. Relocate installing site. 2. Replace new battery.
9	RKP control failure	Incorrect wiring between RKP and Panel.	Verify correct wiring.

7. SYSTEM SPECIFICATIONS

Mains power supply	110 VAC \pm 10% or 230 VAC \pm 10%
Power consumption	Max. 2.5 W @ DISARM mode
Protection zone/loop	8 (Incl. 6 intruder, 1 PA and 1 Tamper)
Alarm relay	C-type contact, 250 V 10A(resistive load)
Alarm relay output time	0~999 seconds, programmable
Bell output power	13.8 VDC 200 mA Max.
Strobe output power	13.8 VDC 200 mA Max.
System DC power supply	13.8 VDC 500mA Max.
Back-up power supply	12V, 1.2~3.2AH Lead-acid rechargeable
Fuse	1.5 Amp, 5 x 20 mm
EOL resistor	1.2 ~ 7.2 K Ω , 4.7 K Ω typical
Alarm event memory	Max. 32
Remote Control Keyfob enrollment	Max. 10
System operation codes	Master Code: 1, User Code: 8 Service Code: 1, Installer Code: 1
Trigger Count	1 or 2, factory default 1
Exit/Entry delay time	0~999 seconds, programmable
Bell output time	0~99 minutes, programmable
Strobe output time	Latched until properly reset.
Chime time	0~9 seconds, programmable.
Operation temperature	-10°C ~ 50°C (14°F ~ 122°F)
Dimensions	260 x 210 x 80 mm

While seeking performance improvement, manufacturer reserves the right to alter the specifications without giving prior notice.