

TECHNICAL DATASHEET

MS-320LP Low Power PIR Motion Sensor Module

INTRODUCTION

IR-TEC MS-320LP is a multipurpose, low power Passive Infrared Motion Sensor Module designed to detect the human movement within its 90° wide angle, 10m long detection range. This is an extremely low power sensor module ideal to integrate with battery or solar powered products. The TTL open collector output and CdS photocell sensor make this module a perfect partner for various OEM product integrations. This module employs a dual element pyroelectric infrared sensor and advanced signal processing circuit to provide following features;

- Excellent motion detection capability.
- Wide operation power voltage range.
- Excellent RFI/EMI protection design.
- Dual stage noise cancellation circuit.
- 90° wide angle Fresnel lens built-in.
- Extremely low power consumption.
- TTL open collector digital output.
- Built-in CdS photocell sensor.
- Ideal for wall mount installation.

APPLICATIONS

The MS-320LP Passive Infrared Motion Sensor is ideal for the following OEM product integrations.

- Wireless intrusion detectors
- Wireless lighting control sensors
- Wireless HVAC ventilation control sensors
- Battery operated motion activated devices
- Portable devices require motion sensors
- Activity detection devices
- Inactivity alerting devices

BLOCK DIAGRAM

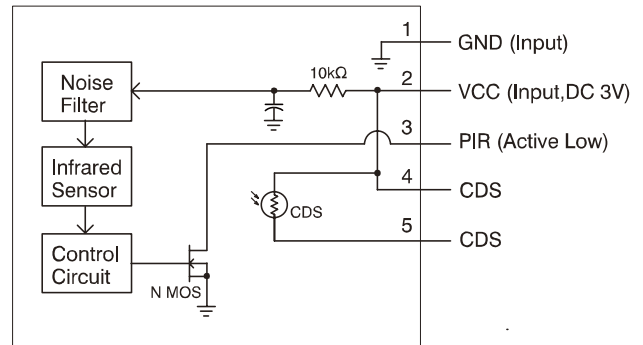

REFERENCE CIRCUIT

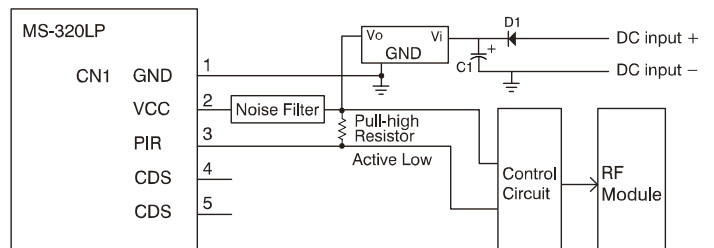

LOGIC DIAGRAM

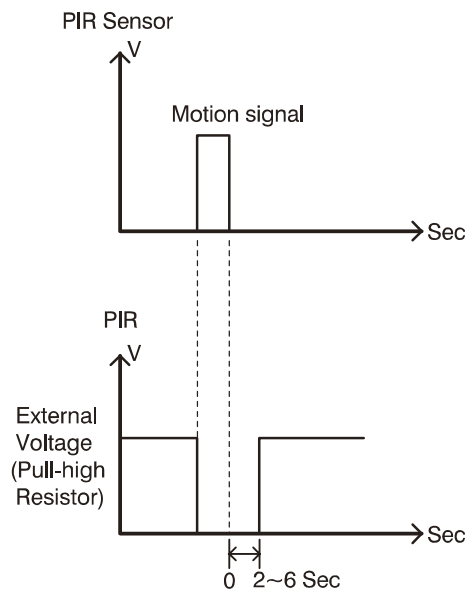

TECHNICAL DATASHEET

DIMENSIONS

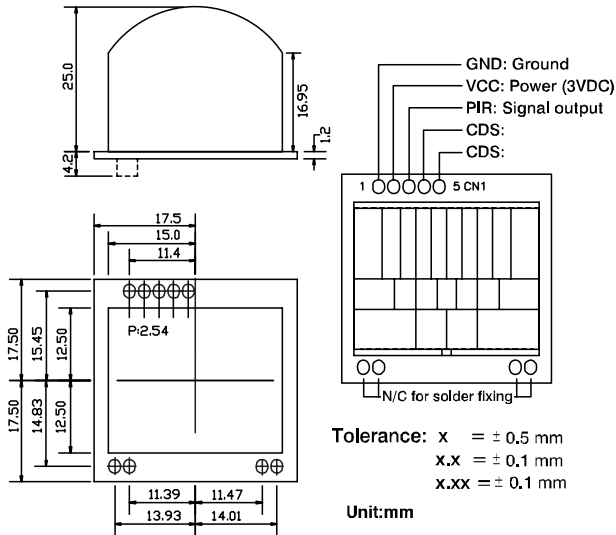

DETECTION PATTERN

Wall Mount

Top View

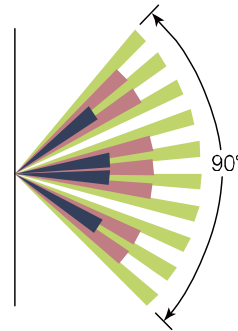

Side View

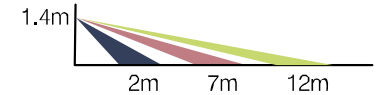

M/H	1.4m	1.6m	1.8m	2.0m	2.2m	2.4m
MAX. Detection Coverage (M)	12	12	12	12	12	12

M/H: Mounting height

DESIGN NOTICES

- If maximum detection coverage is required, please do not block any segment on the optical lens. Masking the respective segments with infrared blocking material on the lens will proportionally block the detection coverage.
- The PIR sensor is more sensitive to the movements across (crosswise) the sensor than toward (longitudinal) it.
- Ensure to provide a clean and regulated DC power to the module to assure reliable detection.

SPECIFICATIONS

Infrared sensor	Dual element pyroelectric
Light sensor	CdS photocell
Operation power (V _{cc})	3±0.5 VDC
Current drain (I _w)	< 10uA
CdS resistance	35 ~ 70 KΩ @10 lux
CdS Gamma value	Typical 0.75, 10 ~ 100 lux
Warm-up time	40±5 seconds
Signal output format	Open collector, Active Low
Signal output time	3 seconds (Typ.)
Detection range @25°C	12m @1.4m height
Mounting height	1.4 ~ 2.4 m (4.6 ft~7.9 ft)
Detectable speed	0.15 ~ 3 m/sec.
Op. temperature	-20°C ~ 50°C (-4°F ~ 122°F)
Maximum output voltage	30 VDC
Maximum output current	100mA (sink)
Dimensions	35 x 35 x 30 mm

Specifications are subject to change without prior notice.