

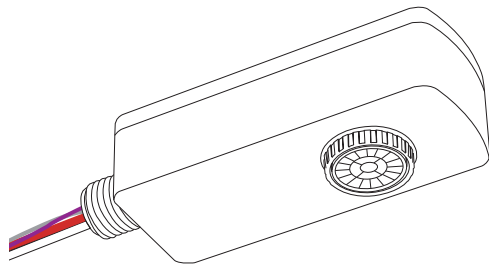

ON-LRD-209SP

Line Voltage OS-NET Sensor

INSTALLATION INSTRUCTIONS



INTRODUCTION

The ON-LRD-209SP is a low profile OS-NET Sensor (ONS) packed with multiple control functionalities including occupancy/vacancy sensing, daylight harvesting, bi-level StepDIM or continuous SmartDIM, and wireless mesh networking capability for top-notch intelligent lighting control.

This batten mount sensor can be integrated with general luminaires through a 1/2" knockout hole. A low profile flat lens provides excellent occupancy sensing capability within its coverage of 2X mounting height. With ON-LRD-209SP, you can easily achieve code-compliant, energy efficient smart lighting control through a wireless sensor mesh network effortlessly deployed while installing the OS-NET enabled luminaires in commercial environments.

SPECIFICATIONS

| | |
|-------------------|---|
| Power supply | 120/230/277VAC, 50/60Hz |
| Maximum Load | Ballast Electronic (LED)-500VA |
| Infrared sensor | Digital quad-element pyroelectric sensor |
| Dim control | 0-10V, ±5%, isolated, max 25mA |
| HIC protection | Max. 80A for 16.7msec. |
| Wireless protocol | Modified Zigbee Light Link (ZLL) |
| Radio frequency | 2405~2480MHz |
| Number of Channel | 16ch |
| Radio range | 5 m (16 ft) @ indoor only |
| Detectable speed | 0.15 ~ 3 m/sec. (0.5~10 ft./sec.) |
| Mounting height | 2.4~6 m (8~20 ft) |
| Remote range | Typ. 10 m (33 ft), indoor with no backlight |
| Op. humidity | Max. 95% RH |
| Op. temperature | -40°C~70°C (-40°F~158°F) |
| Dimensions | 140x48x40mm (5.51"x1.89"x1.50") |

DIMENSIONS

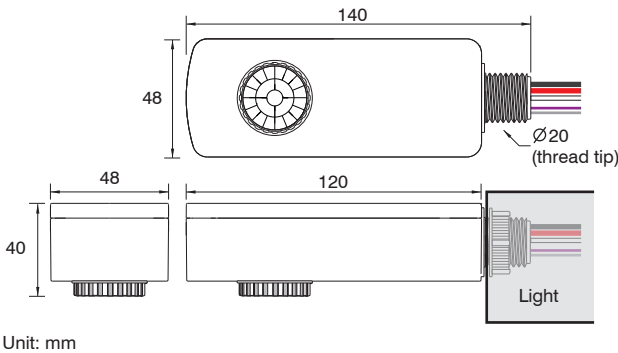

WARNING & CAUTION

- Risk of Electric Shock - Disconnect power supply before servicing.
- Do NOT touch the square window of infrared sensor under the lens assembly.
- Open Type Photoelectric Switches.
- Install this device in accordance with electrical codes and protect with circuit breaker.
- Install the sensor at least 1 ft. away from any occupant.

AVERTISSEMENT & PRUDENCE

- Risque de choc électrique - Débranchez l'alimentation avant l'entretien.
- Ne PAS toucher la fenêtre carrée de capteur infrarouge sous l'ensemble de l'objectif.
- Ouvrir Type commutateurs optoélectroniques.

WIRING DIAGRAM

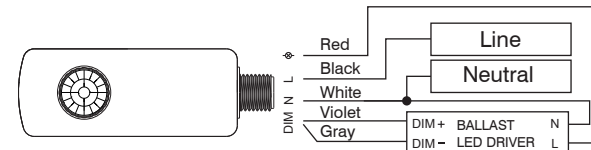

NOTE:

1. Use 0/1-10V dimmable driver/ballast to enable dimming control.
2. Ensure to connect the LINE and NEUTRAL wires correctly. Reverse connection may damage the sensor permanently.
3. Ensure TOTAL isolation between DIM+/DIM- and GROUND of line voltage to avoid damaging the sensor.
4. Always conduct factory test with GROUND connected.

APPLICATION NOTES

1. The sensor is more sensitive to the movements "crossing" the detection zones than "toward" or "away" the sensor unit. To obtain better sensitivity, avoid placing the sensor in line with occupant path.
2. The closer the movement is to the sensor, the more sensitive the sensor is. The higher the sensor is installed, the larger movement is required to be detected.
3. Ensure to place the sensor at least at 1.5m (5 ft.) away from air supply ducts as rapid air flow may cause false activations.
4. The sensor cannot "see" the movements behind obstacles, such as tall furniture, shelf, glass or partitions. Avoid placing the sensor where obstructions may block the sensor's line of sight.
5. The partition of workstation could block the sensor view to occupant movements, it is best to place the sensor over the intersection of workstation. For large open office, place multiple sensors so that there is overlap coverage with each adjacent sensor.
6. To obtain optimal wireless communication range, avoid enveloping the sensor with a metallic enclosure.

DETECTION COVERAGE

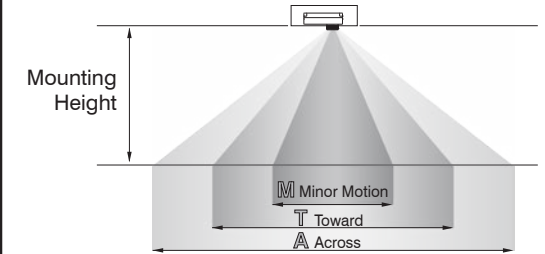

| | | | | | |
|-------------------|---|---------------|---------------|---------------|---------------|
| Mounting Height | | 2.4 m (8 ft) | 3.0 m (10 ft) | 3.6 m (12 ft) | 6.0 m (20 ft) |
| Coverage Diameter | M | 1.0 m (3 ft) | 2.0 m (7 ft) | 3.0 m (10 ft) | -- |
| | T | 3.0 m (10 ft) | 4.0 m (13 ft) | 5.0 m (16 ft) | 6.0 m (20 ft) |
| | A | 5.0 m (16 ft) | 6.0 m (20 ft) | 7.0 m (23 ft) | 9.0 m (30 ft) |

MOUNTING

- ① Assemble the sensor with fixture via the knockout hole

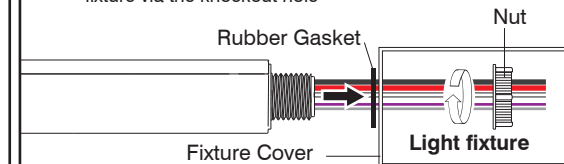

- ② Tighten the screw nut

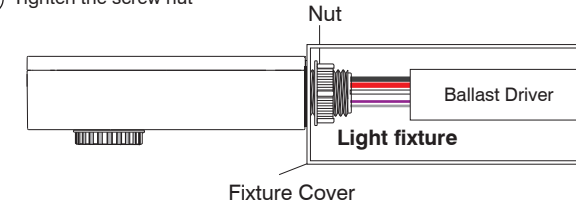

SETTING

All sensor settings can be configured, in individual or group basis, by an OS-NET Remote Programmer SRP-281. Following table highlights the setting items and options available with ON-LRD-209SP. For detailed setting operation, please refer to the OS-NET Programming Guide available for download from www.irtec.com.

Programming Guide



| Settings | Description | Options | Default |
|-------------------------|---|--|-----------|
| INDIV-SET | To setup an individual device | | |
| GROUP-SET | To setup all devices of the group with same settings | | |
| CONTROL | Control schemes available for OS-NET sensor. | ON/OFF, OSO, OSLA, OSLATO, DSVM, DSC, OSB, OFF | OSLATO |
| AMBIENT LUX | Thresholds of ambient light level for OS-NET sensor to execute the control. | 10/20/40/60/80/200/400/600/1000/2000 LUX DISABLED/CURRENT | DISABLED |
| DELAY | Delay time that sensor will turn off or fade down the light. | 30 sec./1/3/5/10/15/20/30/60 min. | 10 min. |
| TIME OFF | Delay time that sensor will keep the light at low dim level after the OFF delay time elapsed. | 10/30 sec./3/5/10/15/20/30/45/60 min. | 10 min. |
| HIGH DIM | High dim is the output level set to control the light during occupancy, or when ambient light is lower than the threshold if daylight sensing scheme is selected. | 50/55/60/65/70/80/90/100%/SmartDIM | 100% |
| LOW DIM/SmartDIM | Low dim is the output level set to dim the light when space is vacant for bi-level control. Low dim setting will become SmartDIM bar if SmartDIM control is selected. | 0/5/10/15/20/25/30/40% | 30% |
| RAMP UP | Speed of lighting output increase. | INSTANT/SOFT/SLOW | INSTANT |
| FADE DOWN | Speed of lighting output decrease. | INSTANT/SOFT/SLOW | SOFT |
| LED INDICATOR | Enable or disable the LED indicator of the sensor. | ENABLED/DISABLED | ENABLED |
| VM-TB | Time duration BEFORE Virtual Midnight. Only available if DSVM is selected. | 0.5/1/1.5/2/2.5/3/3.5/4/4.5/5/5.5/6 hour | 2.5 hours |
| VM-TA | Time duration AFTER Virtual Midnight. Only available if DSVM is selected. | 0.5/1/1.5/2/2.5/3/3.5/4/4.5/5/5.5/6 hour | 4 hours |
| SENSITIVITY | Sensitivity of occupancy sensor. To disable the occupancy sensing capability, select OFF. | HIGH/NORMAL/LOW/OFF | HIGH |

SETTING ACKNOWLEDGEMENT

The sensor will acknowledge setting success or failure with different indications by device LED or connected lighting.

| INDICATION | ACKNOWLEDGEMENT | REMARKS |
|---|--|---|
| Device LED fast blinking in GREEN and BLUE. | The device is scanning and linking to the network. | The fast blinking (on-off per 0.2 second) only appears during network linking. |
| Device LED blinks twice every 2-second in GREEN or BLUE. | The sensor detects occupant's motion. | GREEN means the device is network linked. BLUE means the device is unlinked. |
| Device LED blinks twice every 2-second for 5 minutes, and then 15-second after power applied. | The device is set with daylight sensing control. (DSVM or DSC) | GREEN means the device is network linked. BLUE means the device is unlinked. |
| Device short beeps twice. | Receiving a single setting or control command. | |
| Device beeps one long and two short. The connected lights flash twice. | 1. Multiple setting data UPLOAD successful. 2. GROUP LINK successful. | |
| The connected lights flash twice. | 1. Factory default setting resumed. 2. SmartDIM setting completed. | Industry Canada statement: IC: 22993-209RS4C901 |

Federal Communication Commission Interference Statement FCC ID: NRIRS420900

This device complies with Part 15 of the FCC Rules. Operation is subject to the following two conditions: (1) This device may not cause harmful interference, and (2) this device must accept any interference received, including interference that may cause undesired operation.

This equipment has been tested and found to comply with the limits for a Class B digital device, pursuant to Part 15 of the FCC Rules. These limits are designed to provide reasonable protection against harmful interference in a residential installation. This equipment generates, uses and can radiate radio frequency energy and, if not installed and used in accordance with the instructions, may cause harmful interference to radio communications. However, there is no guarantee that interference will not occur in a particular installation. If this equipment does cause harmful interference to radio or television reception, which can be determined by turning the equipment off and on, the user is encouraged to try to correct the interference by one of the following measures:

-Reorient or relocate the receiving antenna.
-Increase the separation between the equipment and receiver.
-Connect the equipment into an outlet on a circuit different from that to which the receiver is connected.
-Consult the dealer or an experienced radio/TV technician for help.

FCC Caution: Any changes or modifications not expressly approved by the party responsible for compliance could void the user's authority to operate this equipment.

This transmitter must not be co-located or operating in conjunction with any other antenna or transmitter.

Radiation Exposure Statement:
This equipment complies with FCC radiation exposure limits set forth for an uncontrolled environment. This equipment should be installed and operated with minimum distance 20cm between the radiator & your body.

This device complies with ISED's licence-exempt RSSs. Operation is subject to the following two conditions: (1) This device may not cause harmful interference, and (2) this device must accept any interference received, including interference that may cause undesired operation.

Le présent appareil est conforme aux CNR d'ISED applicables aux appareils radio exempts de licence. L'exploitation est autorisée aux deux conditions suivantes : (1) le dispositif ne doit pas produire de brouillage préjudiciable, et (2) ce dispositif doit accepter tout brouillage reçu, y compris un brouillage susceptible de provoquer un fonctionnement indésirable.

Radiation Exposure Statement:
This equipment complies with ISED radiation exposure limits set forth for an uncontrolled environment. This equipment should be installed and operated with greater than 20cm between the radiator & your body.

Déclaration d'exposition aux radiations:
Cet équipement est conforme aux limites d'exposition aux rayonnements ISED établies pour un environnement non contrôlé. Cet équipement doit être installé et utilisé à plus de 20 cm entre le radiateur et votre corps.

CONTROL SCHEME

The ON-LRD-209SP series can be programmed to control the connected lighting in one of the schemes as below.

| Scheme | Description |
|---------------|--|
| ON/OFF | This is a typical occupancy sensing control scheme. Lighting will be inhibited when the ambient light level is higher than the set threshold, regardless of occupancy or vacancy. When the ambient light level is lower than the set threshold, the controlled light will be automatically turned on once the sensor detects the presence of occupant, and turned off after the delay time elapsed. NOTE: This scheme can be used with dimmable or non-dimmable lighting, but not for HID lighting. |
| OSO | This is an occupancy sensing control scheme can be applied in areas that require 24-hour lighting. When space is vacant, the lights will be maintained at Low Dim level. Whenever space is occupied, lighting output will be increased to High Dim level or continuously regulated to maintain within the pre-set range by SmartDIM control. NOTE: Do NOT use this scheme to control non-dimmable lighting. |
| OSLA | This is an occupancy sensing control scheme can be applied in spaces that require automatic lighting when the ambient light level is lower than the set threshold. Lighting will be inhibited if the ambient light level is higher than the set threshold, regardless of occupancy or vacancy. When the ambient light level is lower than the set threshold, the sensor will automatically control the light at Low Dim level. When sensor detects the presence of an occupant, lighting output will be increased to the High Dim level or continuously regulated within the pre-set range by SmartDIM control. After the delay time elapsed, lighting output will be reduced to Low Dim level or shut off if the ambient light is higher than the set threshold. NOTE: Do NOT use this scheme to control non-dimmable lighting. |
| OSLATO | This is an occupancy sensing control scheme can be applied in spaces that require maintaining Low Dim lighting for a period of time before shutting off. Lighting will be inhibited if the ambient light level is higher than the set threshold, regardless of occupancy or vacancy. When the ambient light level is lower than the set threshold, and any sensor detects the presence of occupant, lighting output will be increased to High Dim level or continuously regulated to maintain overall lighting level within the pre-set range by SmartDIM control. After the delay time elapsed, lighting output will be reduced to Low Dim level for a period of TIME OFF delay before shut off. NOTE: This scheme requires dimmable lighting to enable dimming control. If lighting is non-dimmable , there will be no dim control and the delay time will be extended with the TIME OFF (TO) delay. |
| DSVM | This is a daylight sensing control scheme can be applied in spaces that require automatically dimming the lighting output to a low level between a certain time before and after virtual midnight. Lighting will be inhibited if the ambient light level is higher than the set threshold. When the ambient light level is lower than the set threshold, the sensor will turn the light to High Dim level or continuously regulate the output to maintain overall lighting level within the pre-set range by SmartDIM control. Lighting output will be reduced to Low Dim level from a certain time before virtual midnight to a certain time after. NOTE: This scheme requires dimmable lighting to enable dimming control. If lighting is non-dimmable , all lights will remain on whenever ambient light level is lower than the set threshold. |
| DSC | This is a daylight sensing control scheme can be applied in spaces that require automatic lighting whenever the ambient light is lower than the set threshold. The sensor will automatically turn on the light to High Dim level or continuously regulate the output to maintain overall lighting level within the pre-set range by SmartDIM control when the ambient light level is lower than the set threshold, and automatically turn off the light when the ambient light level is higher than the set threshold. NOTE: This scheme requires dimmable lighting to enable dimming control. If lighting is non-dimmable , all lights will remain on whenever ambient light level is lower than the threshold. |
| VSC | This is a vacancy sensing control scheme can be applied in spaces that require users to manually turn on the light, and have the sensor turn off the light automatically. The occupant would have to press the OS-NET Button to turn on the lighting group assigned. The sensor will control the lights at High Dim level or continuously regulate the output to maintain overall lighting level within the pre-set range by SmartDIM control. The sensor will control the connected lighting as per OSLATO scheme. NOTE: This scheme requires dimmable lighting to enable dimming control. If lighting is non-dimmable , there will be no dim control and the delay time will be extended with the TIME OFF (TO) delay. |
| OSB | This is an advanced occupancy sensing control scheme can be applied in open offices to provide background light level before the area of entire lighting group is vacant. Lighting will be inhibited if the ambient light level is higher than the set threshold, regardless of occupancy or vacancy. When the ambient light level is lower than the set threshold and the first occupant is detected by a grouped sensor, the output of sensor connected light will be increased to High Dim level or continuously regulated within the pre-set range by SmartDIM control during occupancy, and the unoccupied areas of entire lighting group will brighten up to Low Dim level as background light. The entire lighting group turns off after the last person leaves and delay time elapsed. NOTE: Do NOT use this scheme to control non-dimmable lighting. |
| OFF | This is a manual control scheme can be used when you need the light to be off for a certain period of time. Once this scheme is set, all OS-NET controlled lighting will remain off until another scheme is selected. |