

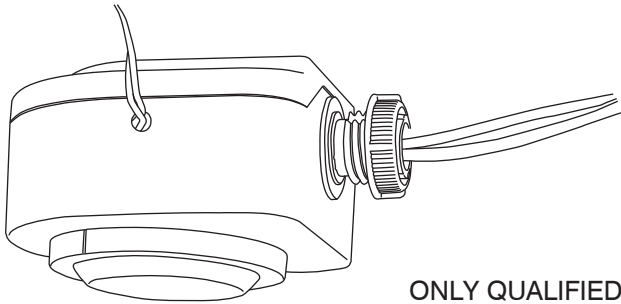

ON-PPU-303

OS-NET Demand Response Controller

INSTALLATION INSTRUCTIONS



**ONLY QUALIFIED
ELECTRICIANS
SHOULD INSTALL
THIS DEVICE.**

Indoor dry location use only

Utilisation a l'interieur Uniquement

⚠ WARNING & CAUTION

- TURN POWER OFF AT CIRCUIT BREAKER BEFORE INSTALLING THIS DEVICE.
- Risk of Electric Shock – More than one disconnect switch may be required to de-energize the equipment before servicing.
- Use UL listed wires for all wiring connections. Low voltage wiring connection should use at least 22 AWG wire. Load switching wiring connection should use at least 12 AWG. AC power line voltage wiring connection should use at least 18 AWG wire. Wire all Class 2 circuits using types CL3, CL3P, CL3R, or equivalent conductors. For plenum return ceilings, use UL listed plenum-approved cables.
- Always check national, state and local building codes for necessary compliance. After initial wiring is complete, ensure to verify all the low and high voltage wires are correctly connected before applying the power. Incorrect wiring could possibly cause permanent damage to the power pack, lighting system, occupancy sensors or other control devices.

⚠ AVERTISSEMENT & PRUDENCE

- COUPER LE COURANT AU DISJONCTEUR AVANT D'INSTALLER BLOCS D'ALIMENTATION.
- Risque de choc électrique – Plus d'un interrupteur peut être nécessaire pour mettre hors tension le matériel avant l'entretien.
- Utiliser homologation UL fils pour toutes les connexions de câblage. Basse tension connection de câblage doit utiliser au moins 22 fils de AWG. Commutation de charges connexions de câblage doit utiliser au moins 12 AWG. Tension de la ligne de courante alternative connexions de câblage doit utiliser au moins 18 fils de AWG. Brancher tous les circuits de classe 2 à l'aide de types CL3, CL3P, CL3R, ou conducteurs équivalent. Pour les plafonds de retour de plénum, utiliser UL câbles ignifuges approuvés énumérés.
- Toujours vérifier les codes de constructions nationaux, étatiques et locales pour le respect nécessaire et conformité. Après le câblage initial est terminé, assurez-vous de vérifier que tous les fils basse et haute tension sont connectés correctement avant d'appliquer la puissance. Un câblage incorrect pourrait causer des dommages permanents à la batterie d'alimentation, système d'éclairage, aux détecteurs de présence ou autres dispositifs de commande.

OVERVIEW

The ON-PPU-303 is an OS-NET enabled Demand Response Controller designed to provide demand response control (DRC) to comply with building energy code requirement. By connecting with an OS-NET network, the ON-PPU-303 will transmit a force-off command wirelessly to shut off the associated OS-NET controlled lighting upon receiving the DRC contact signal from control panel. After the DRC signal is disengaged, all OS-NET connected lighting will resume the original control.

This wireless control device can be attached to a junction box, cable tray, or fixture through a 1/2" knockout with the designed threaded nipple and locknut. Through easy and intuitive operation via the SRP-281, a 2-way IR remote programmer, each ON-PPU-303 can be programmed to control up to 4 groups.

With ON-PPU-303, demand response control can be easily achieved via OS-NET wireless smart lighting solution. Whether it is a new construction or retrofit project, OS-NET wireless smart lighting control solution will save you time and cost in installation, commissioning, and user adoption with ease.

Federal Communication Commission Interference Statement FCC ID: NRIRS330100

This device complies with Part 15 of the FCC Rules. Operation is subject to the following two conditions: (1) This device may not cause harmful interference, and (2) this device must accept any interference received, including interference that may cause undesired operation.

This equipment has been tested and found to comply with the limits for a Class B digital device, pursuant to Part 15 of the FCC Rules. These limits are designed to provide reasonable protection against harmful interference in a residential installation. This equipment generates, uses and can radiate radio frequency energy and, if not installed and used in accordance with the instructions, may cause harmful interference to radio communications. However, there is no guarantee that interference will not occur in a particular installation. If this equipment does cause harmful interference to radio or television reception, which can be determined by turning the equipment off and on, the user is encouraged to try to correct the interference by one of the following measures:

- Reorient or relocate the receiving antenna.
- Increase the separation between the equipment and receiver.
- Connect the equipment into an outlet on a circuit different from that to which the receiver is connected.
- Consult the dealer or an experienced radio/TV technician for help.

FCC Caution: Any changes or modifications not expressly approved by the party responsible for compliance could void the user's authority to operate this equipment.

This transmitter must not be co-located or operating in conjunction with any other antenna or transmitter.

Radiation Exposure Statement:
This equipment complies with FCC radiation exposure limits set forth for an uncontrolled environment. This equipment should be installed and operated with minimum distance 20cm between the radiator & your body.

Install the device at least 1 ft. away from any occupant.

INSTALLATION

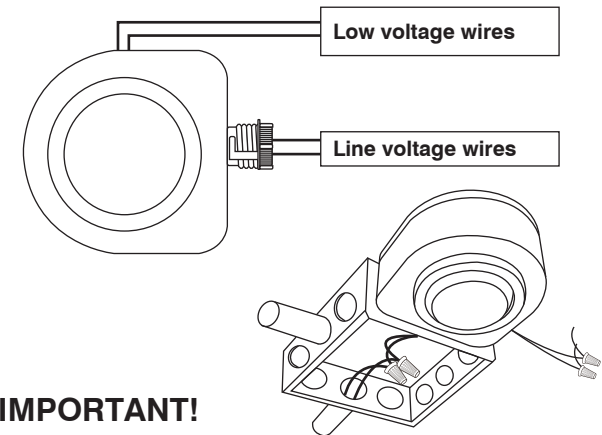

IMPORTANT!

1. All line voltage wiring connections should be made inside of junction box.
2. To obtain optimal wireless communication, avoid placing the device behind a metal mesh/plate.
3. To enable wireless network control, the ON-PPU-303 must be grouped and linked with the other OS-NET devices. An "ungrouped" ON-PPU-303 is functionless.

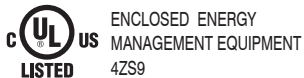

www.irtec.com

P/N: 058-30300-003

Printed in Taiwan

This product may be covered by one or more U.S. patents or patent applications. Please visit www.irtec.com for more information.

WIRING DIAGRAMS

Line Voltage Wires				Low Voltage Wires			
Color	Description	Function	Gauge	Color	Description	Function	Gauge
White	Neutral	Line voltage	18 AWG	Black	DC 0V	DRC	22 AWG Class 2
Black	Line			Blue	Control	Signal input	

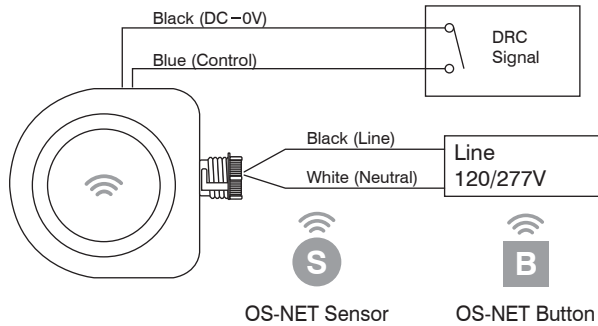

CONFIGURATION

After complete the installation, each OS-NET device should be grouped and linked with the OS-NET network to enable group control. An ungrouped ON-PPU-303 is functionless.

NOTE: For the first time configuration, please learn the basic operation of SRP-281 from the OS-NET Programming Guide.

CREATE A NEW OS-NET NETWORK

NOTE: You may skip this section and start grouping the device if the target network has been created.

To create a new OS-NET network, you can use EZ-GROUP to group two OS-NET devices with the same group within 1 minute. More details are available from the OS-NET Programming Guide.

INITIAL GROUPING

Every installed ON-PPU-303 should be assigned with its controlled group(s) to enable group control. For an ungrouped ON-PPU-303, conduct EZ-GROUP process and assign to the group(s) via the OS-NET Remote Programmer (SRP-281). Refer to the EZ-GROUP instructions of Programming Guide for more details.

Programming Guide



CHANGE GROUP

To change the group assignment of an ON-PPU-303, input the new group number(s) on the EZ-GROUP setting page. Assign the ON-PPU-303 to the new group(s) in the same way as INITIAL GROUPING.

DEVICE ACKNOWLEDGEMENT

The ON-PPU-303 will acknowledge setting success or failure with different indications by device LED.

DEVICE LED	ACKNOWLEDGEMENT	REMARKS
Slow blinking (once per 2 seconds) in BLUE.	The device is unlinked.	
Blinks irregularly in BLUE or GREEN.	Receiving commands from the remote.	GREEN means the device is network linked. BLUE means the device is unlinked.
Fast blinking in GREEN and BLUE intermittently.	Scanning for an open network and linking.	
Lit for 2 seconds in GREEN.	Grouping completed.	
Fast blink 3 times in GREEN.	When demand response control is active.	
Slow blink once and fast blink 3 times in GREEN.	When demand response signal disengaged.	

SPECIFICATIONS

Power supply	120/277VAC, 50/60Hz
DRC signal	Dry contact (NO)
Wireless protocol	Modified Zigbee Light Link (ZLL)
Radio frequency	2.4 GHz
Radio range	Typ. 12 m (40 ft) @ indoor
Radio power output	4.60dBm
Remote range	Typ. 5 m (16 ft), indoor with no backlight
Type of control	*Electronic Operated, Independently Mounted
Action Type	*Automatic, Type 1
Ext. Pollution Situation	Degree 2
Impulse Voltage	4000 V Max.
Op. humidity	Max. 95% RH
Op. temperature	-20°C~55°C (-4°F~122°F)
Dimensions	4.37" x 3.54" x 1.80" (111 x 90 x 46mm)

*Based on UL 60730-1 STD provisions.

WARRANTY

IR-TEC International Ltd. warranties this product to be free of defects in materials or workmanship for a period of five years from date of shipment. There are no obligations or liabilities on the part of IR-TEC International Ltd. for consequential damages arising out or in connection with the use or performance of this product or other indirect damages with respect to loss of property, revenue, or profit, or cost of removal, installation or reinstallation.