

# TRANS



## LRD-309SP

Line Voltage SmartDIM Occupancy Sensor

### INSTALLATION INSTRUCTIONS

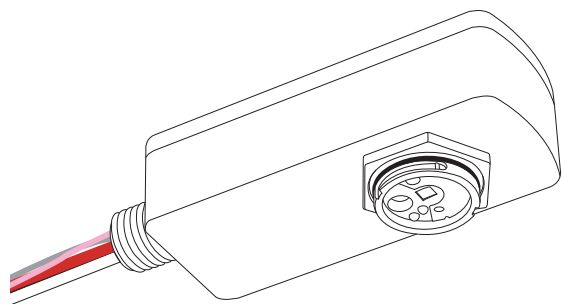

\*This sensor requires lens. Please order separately.  
Refer to the Lens Datasheet for more details.

#### ⚠ WARNING & CAUTION

- Risk of Electric Shock - Disconnect power supply before servicing.
- Do NOT touch the square window of infrared sensor under the lens assembly.
- Open Type Photoelectric Switches.
- Cycling the power to the sensors will cause failure over time.

#### ⚠ AVERTISSEMENT & PRUDENCE

- Risque de choc électrique - Débranchez l'alimentation avant l'entretien.
- Ne PAS toucher la fenêtre carrée de capteur infrarouge sous l'ensemble de l'objectif.
- Ouvrir Type commutateurs optoélectroniques.

### INTRODUCTION

The LRD-309SP is an IP-66 passive infrared (PIR) occupancy sensor designed to deliver multi-scheme occupancy sensing controls to commercial and industrial luminaires equipped with typical or 0-10V dimmable ballasts and LED drivers. This remote-programmable sensor is capable of providing four different control schemes with fully adjustable multi-level high/low StepDIM or SmartDIM control to the integrated lighting. SmartDIM is a state-of-the-art automatic dimming control technology developed by IR-TEC, which enables the sensor to maintain the overall lighting level within the preset range through a smooth and continuous dimming on the controlled lighting. The LRD-309SP also employs an exclusive Hybrid Switching technology to endure switching the LED driver with high inrush current up to 500,000 cycles.

The sensor can be nipple mounted with an OEM luminaire through a 1/2" hole, turn on or ramp up the light to high dim or SmartDIM level as programmed when it detects the presence of an occupant or vehicle, and dim down to low level or shut off the light automatically after the area is vacated for a period of time. A two-way IR handheld remote programmer (SRP-280) allows you to easily configure the control scheme and settings, or download the existing settings of a sensor from the floor. Four EZ-SET profiles can be stored in the SRP-280 for quick setup and parameter adjustment of multiple sensors.

### DIMENSIONS

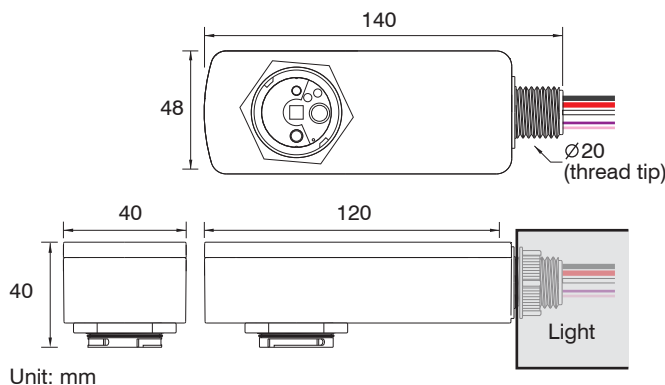

### APPLICATION NOTES

1. The sensor is more sensitive to the movements "crossing" the detection zones than "toward" or "away" the sensor unit. To obtain better sensitivity, avoid placing the sensor in line with occupant path, if possible.
2. The closer the movement is to the sensor, the more sensitive the sensor is. The higher the sensor is installed, the larger movement is required for detection. The warmer the room is, the harder the sensor to detect the movement.
3. Ensure to place the sensor at least at 1.5m (5 ft.) away from air supply ducts as rapid air flow may cause false detections.
4. Avoid placing the sensor where obstructions may block the sensor's line of sight. PIR sensor cannot detect movements through glass.

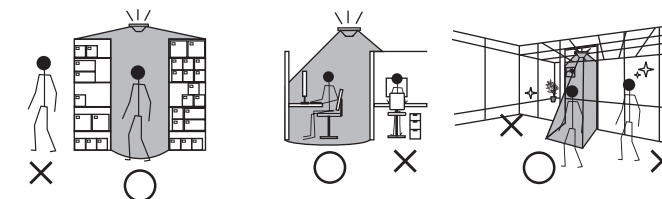

### MOUNTING

- ① Assemble the sensor with fixture via the knockout hole

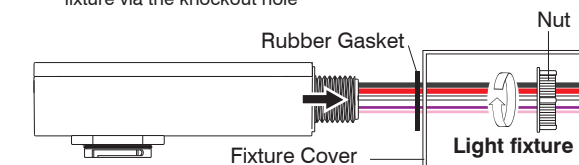

- ② Tighten the screw nut

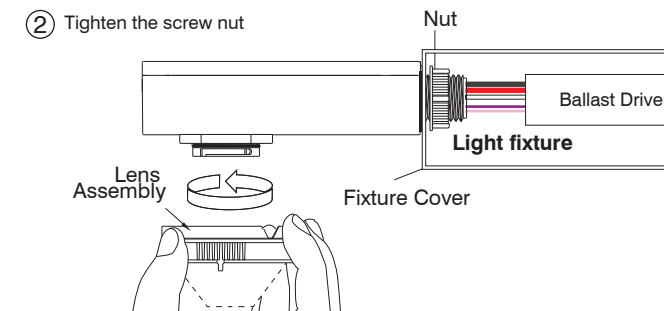

www.irtec.com

P/N: 058-30905-002

Printed in Taiwan

This product may be covered by one or more U.S. patents or patent applications.  
Please visit [www.irtec.com](http://www.irtec.com) for more information.



## CONTROL MODE

The LRD-309SP sensor can be programmed to control the lighting in one of the following modes via a SRP-280 remote programmer. For more details of specific control mode, please visit [www.irtec.com](http://www.irtec.com) or contact an IR-TEC team member directly.

**ON/OFF** : ON-OFF Switching

**OSO** : Occupancy Sensing Only

**OSLA** : Occupancy Sensing at Low Ambient

**OSLATO** : Occupancy Sensing at Low Ambient with Time-Off

Mode	Control
<b>ON/OFF</b>	<ol style="list-style-type: none"> <li>While ambient lux is <b>higher</b> than the level set, light stays <b>OFF</b>.</li> <li>While ambient lux is <b>lower</b> than the level set, and <b>occupancy detected</b>, switch the light to <b>HIGH DIM</b> level set.</li> <li>Turn <b>OFF</b> the light when <b>OFF DELAY</b> elapses.</li> </ol>
<b>OSO</b>	<ol style="list-style-type: none"> <li>Ambient light sensor disabled.</li> <li>Dim the light to <b>LOW DIM</b> set <b>all time</b> under vacancy.</li> <li>Switch the light to <b>HIGH DIM</b> level set under occupancy.</li> </ol> <p>NOTE: The light will remain lit at all time under this mode.</p>
<b>OSLA</b>	<ol style="list-style-type: none"> <li>While ambient lux is <b>higher</b> than the level set, light stays <b>OFF</b>.</li> <li>While ambient lux is <b>lower</b> than the level set, dim the light to <b>LOW DIM</b> level under vacancy.</li> <li>While ambient lux is <b>lower</b> than the level set, and <b>occupancy detected</b>, switch the light to <b>HIGH DIM</b> level and dim the light to <b>LOW DIM</b> level after the <b>OFF DELAY</b> elapses.</li> </ol>
<b>OSLATO</b>	<ol style="list-style-type: none"> <li>While ambient lux is <b>higher</b> than the level set, light stays <b>OFF</b>.</li> <li>While ambient lux is <b>lower</b> than the level set, and <b>occupancy detected</b>, switch the light to <b>HIGH DIM</b> level per <b>OFF DELAY</b> set under occupancy, and dim the light to <b>LOW DIM</b> level during <b>TIME OFF</b> delay set.</li> <li>Switch the light to <b>HIGH DIM</b> level as per <b>OFF DELAY</b> set if <b>occupancy detected</b> during <b>TIME OFF</b>. Turn <b>OFF</b> the light if no <b>occupancy detected</b> after <b>TIME OFF</b> delay elapses.</li> </ol>

## SENSOR ACKNOWLEDGMENT

Acknowledgement	Sensor LED	Beep	Lighting
Full sensor setting upload completed	-	Long x 1 Short x 2	Flash x 2
Sensor resume to factory default	-	-	Flash x 2
SmartDIM level set completed	-	Short x 2	Flash x 2
Single setting ok	-	Short x 2	-
Occupancy detected	Flash x 1	-	-

## SENSOR SETTINGS

The followings are settings and options available with LRD-309SP that can be configured via SRP-280 remote programmer. For more details of remote operation, please refer to the operation instruction of SRP-280.

Settings	Description	Options	Default
<b>CONTROL</b>	The mode that the sensor will control.	ON/OFF, OSO, OSLA, OSLATO	OSLATO
<b>AMBIENT LUX</b>	The ambient light level that sensor will perform the control.	10/20/40/60/100/200/400 LUX/DISABLED	DISABLED
<b>DELAY</b>	The delay time that sensor is set to turn off or dim the light after the area is vacant.	30 sec./1/3/5/10/15/20/30/60 min.	10 min.
<b>TIME OFF</b>	The delay time that sensor will keep the light at low dim level after the OFF delay time elapsed.	10/30 sec./3/5/10/15/20/30/45/60 min.	10 min.
<b>HIGH DIM</b>	The output level set to control the light during occupancy.	50/55/60/65/70/80/90/100%/SmartDIM	100%
<b>LOW DIM/SmartDIM</b>	The output level set to dim the light when space is vacant for bi-level control. Low dim setting will become SmartDIM bar if SmartDIM control is selected.	0/5/10/15/20/25/30/40%	30%
<b>RAMP UP</b>	The speed of increasing the lighting output to HIGH DIM level.	INSTANT/SOFT/SLOW	INSTANT
<b>FADE DOWN</b>	The speed of decreasing the lighting output to LOW DIM level or off.	INSTANT/SOFT/SLOW	SOFT
<b>SENSITIVITY</b>	The sensitivity of occupancy sensor.	HIGH/NORMAL/LOW	HIGH

## WIRING DIAGRAM

### Non-dimmable Lighting (ON-OFF Switching only)

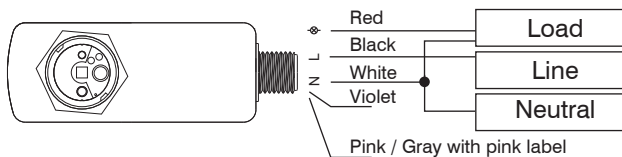

### 0-10V Dimmable Lighting

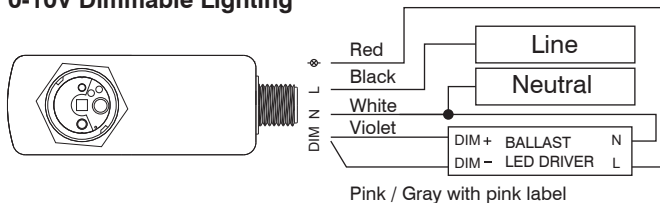

### NOTE:

- To achieve dimming control, the driver/ballast MUST be 0-10V dimmable.
- Incorrect LINE and NEUTRAL wire connections will cause permanent damage of the sensor.

## SPECIFICATIONS

Power supply	100/120/277VAC, 50/60 Hz	
Maximum load	100-120VAC	277VAC
	-Incandescent/Halogen	800/*500W(VA)      1200/*750W(VA)
	-Fluorescent Ballast/CFL	800/*500W(VA)      1200/*750W(VA)
-Ballast Electronic (LED)	540/*500VA	1200/*750VA
Infrared sensor	Digital quad-element pyroelectric sensor	
Photo sensor	Digital ambient light sensor	
HIC protection	Max. 80A for 16.7msec.	
Dim control output	0-10V, ±5%, isolated, max. 25mA	
Detectable speed	0.3 ~ 3 m/sec. (1~10 ft./sec.)	
Mounting height	Subject to the lens type applied	
Detection range	Subject to the lens type and mounting height	
Remote range	10 m (33 ft.) indoor, no backlight	
Op. humidity	Max. 95% RH	
Op. temperature	-40°C~70°C (-40°F~158°F)	
Dimensions	140x48x40mm (5.51"x1.89"x1.50")	

\*Max load for operating temperature at 55°C~70°C (131°F~158°F)