

# MS-360

## PIR Motion Sensor Module



### OVERVIEW

IR-TEC's MS-360 is a multipurpose, low cost Passive Infrared Motion Sensor Module designed for OEM applications. This sensor is able to detect the human body motion within its detection range and output a TTL open collector signal output. The sensor employs a dual element pyroelectric infrared sensor and advanced electronics circuit to provide following outstanding features.

### DIMENSIONS

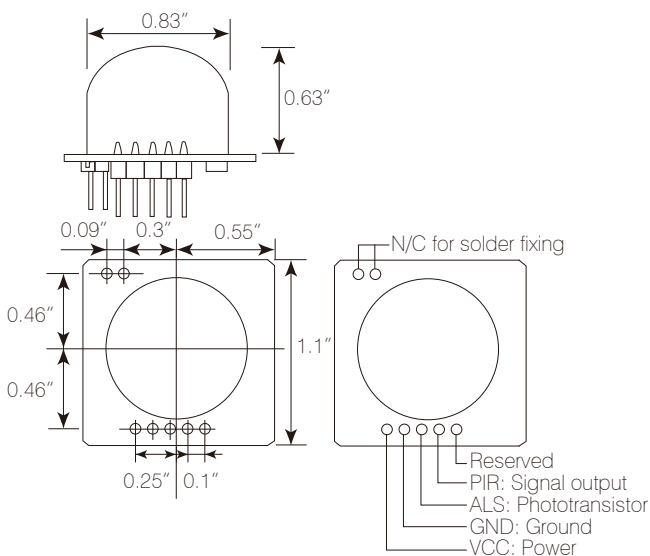

### FEATURES

- Excellent motion detection capability
- Wide operation power voltage range
- 360° detection compact dome lens
- Low operation power consumption
- TTL open collector digital output
- Built-in Ambient Light Sensors (ALS)
- Available for ceiling/wall mount device

### APPLICATION

IR-TEC MS-360 Passive Infrared Motion Sensor can be integrated with the following OEM products.

- Light control sensor
- HVAC thermostat
- Toilet ventilation fan
- Indoor air quality filter
- Vending machine

### DETECTION PATTERN

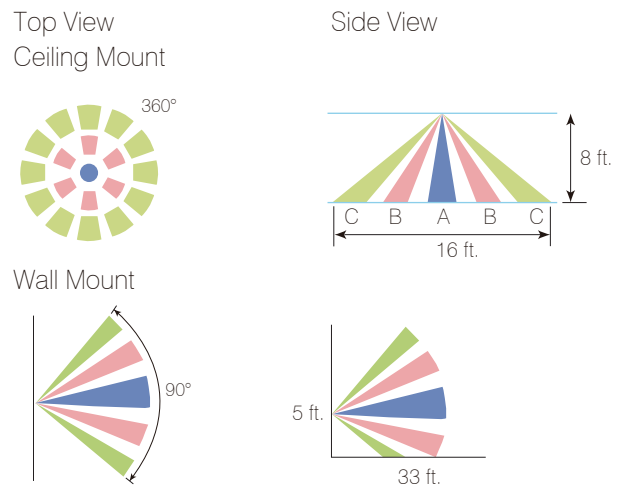

### BLOCK DIAGRAM

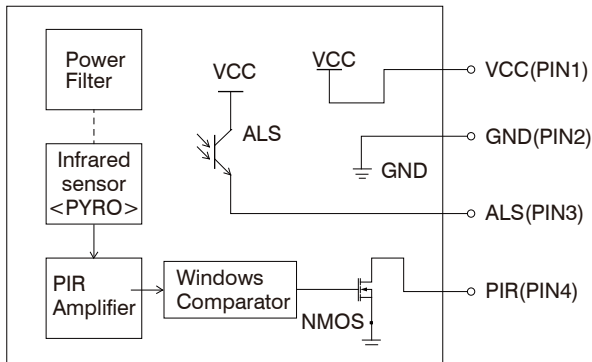

### REFERENCE CIRCUIT

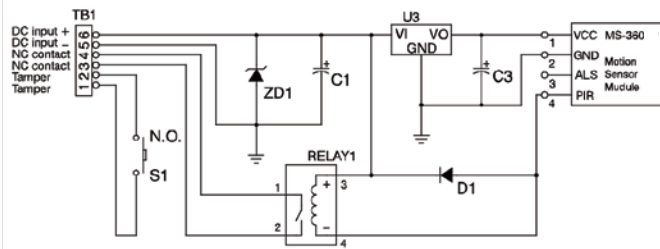

### REFERENCE ALS TEST

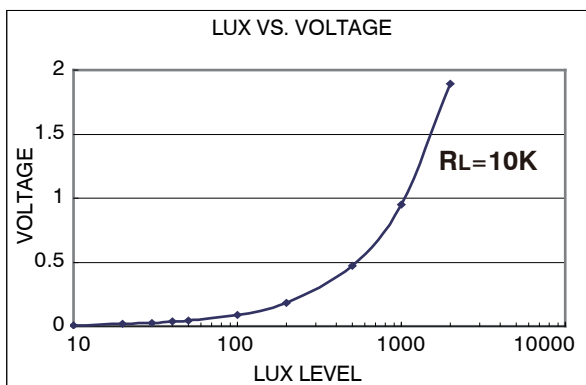
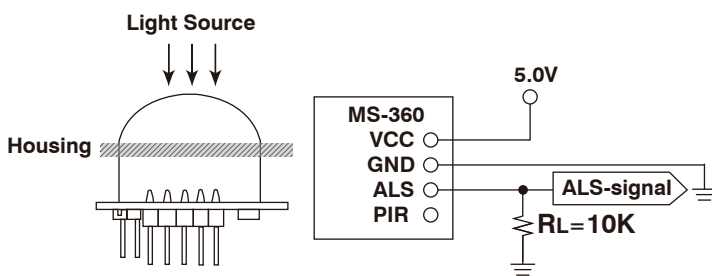

### DESIGN NOTICES

If maximum detection coverage is required, please do not block any segment of dome lens. Masking the segments of the lens could block the detection respectively. The sensor is more sensitive to the movements across (crosswise) the sensor than toward (longitudinal) it. Ensure to provide clean and stable power to the module to assure its detection reliability.

### SPECIFICATIONS

Power supply	5 ± 1.5VDC
Current drain	<1mA
Infrared sensor	Dual element, high sensitivity, low noise
Sensor output	Open collector, Active Low
Output period	1 ~ 2.5 sec.
Max. power voltage	7VDC
Max. output voltage	30VDC
Max. output current	100mA (sink)
Light sensor	ALS
ALS dark current	Max. 0.1uA @ 77°F (25°C)
Peak sensitivity wavelength (λp)	630nm
Sensitivity wavelength range (λ)	390 ~ 700nm
Detection range	Ceiling: 16 ft. @ 8 ft. high (5m @ 2.4m high) Wall: 33 ft., 90° wide (10m)
Detectable speed	0.5 ~ 10 ft./sec. (0.15 ~ 3m/sec.)
Detection zones	38 zones
I/O connection	0.1" (2.54mm), 4 x 1 pin connector
Fresnel lens	Ø0.8" (21mm) dome Fresnel lens
Mounting height	Ceiling: 6 ~ 10 ft.(1.8 ~ 3m) Wall: 4 ~ 6 ft.(1.2 ~ 1.8m)
Warm up time	Approx. 50 sec.
Temperature	-4°F ~ 122°F (-20°C ~ 50°C)
Dimensions	1.1" x 1.1" x 0.63" (28 x 28 x 16mm)

Specifications are subject to change without prior notice.