



OVERVIEW

The ON-PPU-301 is an OS-NET enabled power pack and plug load controller featuring state-of-the-art wireless mesh network capability for achieving top-notch intelligent lighting control. This power pack not only supplies 24 VDC power for IR-TEC's low voltage occupancy sensors, but also provides load switching up to 20A upon receiving control signals from wired sensors, or wireless commands from networked OS-NET devices assigned with the same group. A unique radio command will be transmitted to other OS-NET devices for executing coordinated group control when ON-PPU-301 receives control signal from a wired sensor.

This device can be attached to a junction box, cable tray, or fixture through a 1/2" knockout with the designed threaded nipple and locknut. Subject to the wiring connection and control setting, the ON-PPU-301 can be programmed to provide occupancy/vacancy sensing control to the connected light or plug load control for codes compliance. Numerous control settings, including burn-in time, delay time, group/ungroup, lock/unlock...etc. can be intuitively configured via SRP-281 2-way handheld remote programmer.

With ON-PPU-301, you can easily enable wireless smart lighting control with IR-TEC low voltage occupancy sensors. Zone lighting and plug load controls can be easily done at any junction box or fixture. Combining the ON-PPU-301 with the OS-NET Button gives unparalleled flexibility and ease for room control. Whether it is a new construction or retrofit project, OS-NET will save tremendous amount of time in installation, commissioning, and user adoption.

FEATURES

- OS-NET enabled power pack & load controller
- 120/277VAC universal line voltage operation
- Class 2 switching mode 24VDC power supply
- Controls lighting and load switching up to 20A
- Ideal for zone lighting and plug load controls
- Accept dry contact or active-low open collector
- 2-way IR remote programmable control settings
- One device can be assigned to max four groups
- Dual color LED indicates network linkage status
- Zero-crossing relay contacts switching control

APPLICATION

- Lighting Control
- Plug Load Control

CONTROL SCHEMES

The ON-PPU-301 can be easily programmed via SRP-281 to control the connected lighting in occupancy or vacancy sensing control or occupancy sensing based plug load control.

CONTROL	Description
ON/OFF	The load will be switched ON when ON-PPU-301 receives 1) control signal from a wired low voltage occupancy sensor, or 2) wireless command from a grouped OS-NET Device, and switched OFF when programmed delay time elapses or receives the OFF-command from a grouped OS-NET Button. If load was switched OFF via OFF-command, ON-PPU-301 will operate under presentation mode, the load will remain OFF if motion is detected before the time delay elapse. If no motion has been detected and the time delay elapsed, the ON-PPU-301 will resume to above auto-ON, auto-OFF operation.
VSC	VSC refers to Vacancy Sensing Control. This control requires user to turn ON the load by pressing a grouped OS-NET Button, and the ON-PPU-301 will turn OFF the load when programmed delay time elapses or receives the OFF-command from a grouped OS-NET Button.
PLC	PLC refers to Plug Load Control. The ON-PPU-301 will enable the plug load power when it receives 1) control signal from a wired low voltage occupancy sensor, or 2) wireless command from a grouped OS-NET Sensor/Button, and switch OFF the plug load power after the area is vacant and programmed delay time elapsed.

SPECIFICATIONS

Power supply	120/277 VAC, 60 Hz
DC power output	24 V, 100 mA max.
Maximum load	1 HP @120VAC 1 HP @ 240VAC 20A Resistive @ 120/277VAC 20A Ballast @ 120/277VAC
Control signal	Dry contact or active low open collector
Wireless protocol	Modified Zigbee Light Link (ZLL)
Radio frequency	2.4 GHz
Radio range	Typical 12 m (40 ft.) @ indoor
Remote range	Typ. 5 m (16 ft), indoor with no backlight
Op. humidity	Max 95% RH
Op. temperature	-20°C ~ 55°C (-4°F ~ 122°F)
Dimensions	111 x 90 x 46 mm (4.37" x 3.54" x 1.80")
Purpose of control	Operating Control with Electronic Independently Mounted
Type action	Type 1
External pollution situation	Pollution Degree 2
Rated impulse voltage	4000 V

WIRING DIAGRAMS

A. Occupancy/Vacancy Sensing Control

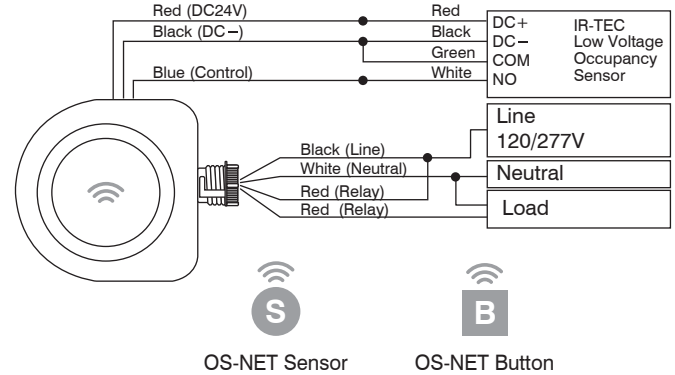

NOTE: For Vacancy Sensing Control (VSC), at least one OS-NET Button should be installed and grouped with the ON-PPU-301 to enable manual-on control.

B. Plug Load Control

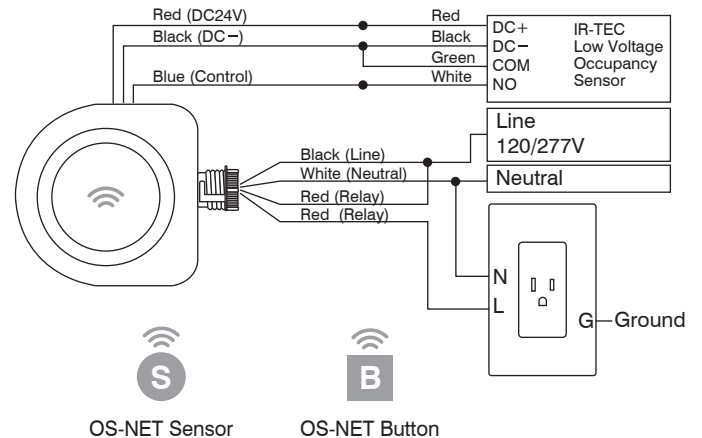

NOTE: If PLC is selected, the OFF-command from OS-NET Button will be ignored.