

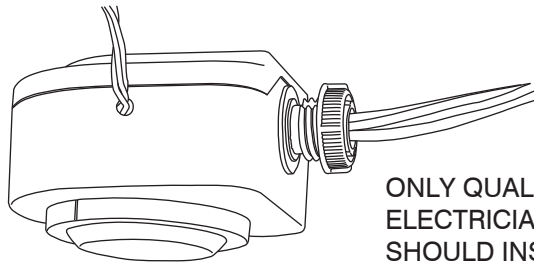

ON-PPU-302

OS-NET Power Pack with 0-10V Dim Control

INSTALLATION INSTRUCTIONS



ONLY QUALIFIED ELECTRICIANS SHOULD INSTALL THIS DEVICE.

Indoor dry location use only
Utilisation a l'interieur Uniquement

APPLICABLE REMOTE (order separately)

Model	Description	Remarks
SRP-281	OS-NET Remote Programmer	Full functionality

WARNING & CAUTION

- TURN POWER OFF AT CIRCUIT BREAKER BEFORE INSTALLING THIS DEVICE.
- Risk of Electric Shock – More than one disconnect switch may be required to de-energize the equipment before servicing.
- Use UL listed wires for all wiring connections. Low voltage wiring connection should use at least 22 AWG wire. Load switching wiring connection should use at least 12 AWG. AC power line voltage wiring connection should use at least 18 AWG wire. Wire all Class 2 circuits using types CL3, CL3P, CL3R, or equivalent conductors. For plenum return ceilings, use UL listed plenum-approved cables.
- Always check national, state and local building codes for necessary compliance. After initial wiring is complete, ensure to verify all the low and high voltage wires are correctly connected before applying the power. Incorrect wiring could possibly cause permanent damage to the power pack, lighting system, occupancy sensors or other control devices.

AVERTISSEMENT & PRUDENCE

- COUPER LE COURANT AU DISJONCTEUR AVANT D'INSTALLER BLOCS D'ALIMENTATION.
- Risque de choc électrique – Plus d'un interrupteur peut être nécessaire pour mettre hors tension le matériel avant l'entretien.
- Utiliser homologation UL fils pour toutes les connexions de câblage. Basse tension connection de câblage doit utiliser au moins 22 fils de AWG. Commutation de charges connections de câblage doit utiliser au moins 12 AWG. Tension de la ligne de courante alternative connections de câblage doit utiliser au moins 18 fils de AWG. Brancher tous les circuits de classe 2 à l'aide de types CL3, CL3P, CL3R, ou conducteurs équivalent. Pour les plafonds de retour de plénum, utiliser UL câbles ignifuges approuvés énuméré.
- Toujours vérifier les codes de constructions nationaux, étatiques et locales pour le respect nécessaire et conformité. Après le câblage initial est terminé, assurez-vous de vérifier que tous les fils basse et haute tension sont connectés correctement avant d'appliquer la puissance. Un câblage incorrect pourrait causer des dommages permanents à la batterie d'alimentation, système d'éclairage, aux détecteurs de présence ou autres dispositifs de commande.

INTRODUCTION

The ON-PPU-302 is an OS-NET enabled power pack featuring 0-10V dim control output and state-of-the-art wireless mesh network capability for achieving top-notch intelligent lighting control. This power pack not only supplies 24 VDC power for IR-TEC's low voltage occupancy sensors, but also provides line voltage load switching up to 20A with 0-10V dim control output upon receiving contact signals from the wired sensors, or wireless commands from the networked OS-NET devices of the same group. A specific radio command will be transmitted to other OS-NET devices for executing coordinated group control whenever ON-PPU-302 receives the control signal from a wired sensor. Each ON-PPU-302 can be a member of up to 4 groups.

This device can be attached to a junction box, cable tray, or fixture through a 1/2" knockout with the designed threaded nipple and locknut. Subject to the control setting, the ON-PPU-302 can be programmed to provide occupancy/vacancy sensing control to the connected light. Numerous control settings, including burn-in time, delay time,

group/ungroup, lock/unlock...etc. can be intuitively configured via SRP-281 2-way handheld remote programmer.

With ON-PPU-302, you can easily enable wireless smart lighting control with IR-TEC low voltage occupancy sensors. Zoning lighting now become very easy and can be done at any junction box or fixture. Combining the ON-PPU-302 with the OS-NET Button offers unparalleled flexibility and ease for room control that requires dimming capability. Whether it is a new construction or retrofit project, OS-NET wireless smart lighting control solution will save time and cost in installation, commissioning, and user adoption with ease.

SPECIFICATIONS

Power supply	120/277 VAC, 60 Hz
DC power output	24 V, 100 mA max.
Maximum load	20A @120/277VAC, LED/ballast
Control signal	Dry contact or active low open collector
Dim control	0-10V, sink <25mA
Wireless protocol	Modified Zigbee Light Link (ZLL)
Radio frequency	2.4 GHz
Radio range	Typical **12 m (40 ft.) @ indoor
Radio power output	4.60dBm
Remote range	Typ. 5 m (16 ft), indoor with no backlight
Type of control	*Electronic Operated, Independently Mounted
Action Type	*Automatic, Type 1
Ext. Pollution Situation	Degree 2
Impulse Voltage	4000 V Max.
Op. humidity	Max 95% RH
Op. temperature	-20°C ~ 55°C (-4°F ~ 122°F)
Dimensions	111 x 90 x 46 mm (4.37" x 3.54" x 1.80")

*Based on UL 60730-1 STD provisions.

**Actual radio range may differ depending on environmental conditions.

Federal Communication Commission Interference Statement FCC ID: NRIRS330100

This device complies with Part 15 of the FCC Rules. Operation is subject to the following two conditions: (1) This device may not cause harmful interference, and (2) this device must accept any interference received, including interference that may cause undesired operation.

This equipment has been tested and found to comply with the limits for a Class B digital device, pursuant to Part 15 of the FCC Rules. These limits are designed to provide reasonable protection against harmful interference in a residential installation. This equipment generates, uses and can radiate radio frequency energy and, if not installed and used in accordance with the instructions, may cause harmful interference to radio communications. However, there is no guarantee that interference will not occur in a particular installation. If this equipment does cause harmful interference to radio or television reception, which can be determined by turning the equipment off and on, the user is encouraged to try to correct the interference by one of the following measures:

- Reorient or relocate the receiving antenna.
- Increase the separation between the equipment and receiver.
- Connect the equipment into an outlet on a circuit different from that to which the receiver is connected.
- Consult the dealer or an experienced radio/TV technician for help.

FCC Caution: Any changes or modifications not expressly approved by the party responsible for compliance could void the user's authority to operate this equipment.

This transmitter must not be co-located or operating in conjunction with any other antenna or transmitter.

Radiation Exposure Statement:
This equipment complies with FCC radiation exposure limits set forth for an uncontrolled environment. This equipment should be installed and operated with minimum distance 20cm between the radiator & your body.

Install the device at least 1 ft. away from any occupant.

INSTALLATION

Line Voltage Wires				Low Voltage Wires			
Color	Description	Function	Gauge	Color	Description	Function	Gauge
White	Neutral	Line voltage	18 AWG	Red	DC24V	DC power supply	22 AWG Class 2
Black	Line			Black	DC-		
Red	Relay contacts	Load switching	12 AWG	Blue	Control	0-10V	
Red				Violet	DIM+		

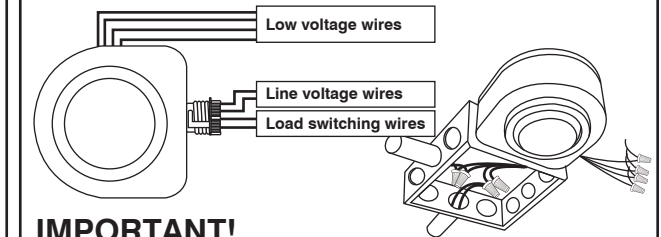

IMPORTANT!

- Actual radio range may differ depending on environmental conditions. Always do a site survey to understand existing Wi-Fi usage.
- Ensure to place the device at least at 1.5m (5 ft.) away from any Wi-Fi router as they can mask or delay signals.
- All line voltage wiring connections should be made inside of junction box.
- To obtain optimal wireless communication, avoid placing the device behind a metal mesh/plate.
- To enable wireless network control, the ON-PPU-302 must be grouped and linked with the other OS-NET devices. An "ungrouped" ON-PPU-302 with low voltage occupancy sensor connected will only operate in standalone control.

WIRING DIAGRAMS

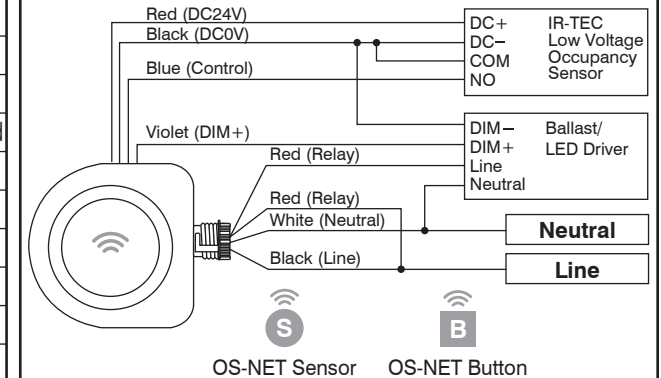

NOTE: For Vacancy Sensing Control (VSC), at least one OS-NET Button should be installed and grouped with the ON-PPU-302 to enable manual-on control.

SETTING

The ON-PPU-302 can be configured to link with other OS-NET devices wirelessly to execute specific control via SRP-281. For more details about remote operation, please refer to the OS-NET Programming Guide available from www.irtec.com.

Programming Guide



Settings	Description	Options	Default
INDIV-SET	To setup an individual device		
GROUP-SET	To setup all devices of the group with same settings		
CONTROL	Control schemes available for ON-PPU	ON/OFF, OSO, OSLATO, VSC	OSLATO
HIGH DIM	High dim is the output level set to control the light during occupancy	50/55/60/65/70/80/90/100%	100%
LOW DIM	Low dim is the output level set to dim the light when space is vacant for bi-level control	0/5/10/15/20/25/30/40%	30%
DAY/NIGHT SYNC	Sync day night status with PRIMARY sensor when set as SECONDARY	SECONDARY/DISABLED	DISABLED
DELAY	Delay time that ON-PPU will turn off or fade down the light	30 sec./1/3/5/10/15/20/30/60 min.	10 min.
TIME OFF	Delay time that ON-PPU will turn off load	10/30 sec./3/5/10/15/20/30/45/60 min.	10 min.
RAMP UP	Speed of lighting output increase	INSTANT/SOFT/SLOW	INSTANT
FADE DOWN	Speed of lighting output decrease	INSTANT/SOFT/SLOW	SOFT
LED INDICATOR	Enable/disable the LED indicator	ENABLED/DISABLED	ENABLED
MIN. DIM	The lowest dim level applicable	12/15%/DISABLED	DISABLED

DEVICE LED ACKNOWLEDGEMENT

The device will acknowledge the setting success or failure with following indications by device LED in BLUE or GREEN. BLUE means the device is unlinked and GREEN means the device is network linked.

Device Led	Acknowledgement
LED on	Control scheme is set to ON/OFF scheme
Slow blinking (on-off per 0.5 second)	Control scheme is set to VSC scheme
Blink slow twice and fast once	Control scheme is set to OSO scheme
Blink slow twice and fast twice	Control scheme is set to OSLATO scheme
Blinks irregularly in BLUE or GREEN	Receiving commands from the remote
Fast blinking in BLUE and GREEN intermittently	Scanning for an open network and linking
Blinks slow once and fast twice	The device is under test mode
Blinks slow once and fast once	The device is under burn-in mode
Lit for 2 seconds in GREEN	Grouping/setting is completed
The connected lights flash twice	1. Factory default setting resumed 2. Multiple setting data UPLOAD successful

CONTROL SCHEME

The following schemes can be programmed via CONTROL setting of the SRP-281. Depending on the connection of wired **Low Voltage Occupancy Sensor (LVOS)** and grouped **OS-NET Sensor (ONS)/OS-NET Button (ONB)**, the ON-PPU may control the load in slightly different patterns.

CONTROL = ON/OFF

The load will be switched ON when ON-PPU receives 1) control signal from a wired LVOS, or 2) wireless command from a grouped ONS/ONB, and switched OFF when programmed delay time elapses or receives the OFF-command from a grouped OSB.

If the load was switched OFF via an OSB, the ON-PPU will operate in Presentation Mode. The load will remain OFF if motion is detected before the delay time elapse. The ON-PPU will resume to auto-ON, auto-OFF control after delay time elapsed.

“√” means “one or more units connected/grouped”

LVOS	ONS	ONB	ON-PPU-302 Operations	
√	-	-	HIGH DIM	Any LVOS detects occupancy
			Load OFF	Last active LVOS delay elapses
			Delay reset	Not activated
-	√	-	HIGH DIM	Any ONS detects occupancy
			Load OFF	ON-PPU delay elapses
			Delay reset	When ONS detects occupancy
-	-	√	HIGH DIM	Any ONB is pressed ON
			Load OFF	ON-PPU delay elapses or ONB is pressed OFF
			Delay reset	When ONB is pressed ON
√	√	-	HIGH DIM	Any LVOS/ONS detects occupancy
			Load OFF	Both LVOS and ON-PPU delays elapse
			Delay reset	When ONS detects occupancy
√	-	√	HIGH DIM	Any LVOS detects occupancy or ONB is pressed ON
			Load OFF	Last LVOS delay elapses or ONB is pressed OFF
			Delay reset	When ONB is pressed ON
-	√	√	HIGH DIM	Any ONS detects occupancy or ONB is pressed ON
			Load OFF	ON-PPU delays elapse or ONB is pressed OFF
			Delay reset	When ONS detects occupancy or ONB is pressed ON
√	√	√	HIGH DIM	Any LVOS/ONS detects occupancy or ONB is pressed ON
			Load OFF	Both LVOS and ON-PPU delays elapse or ONB is pressed OFF
			Delay reset	When ONS detects occupancy or ONB is pressed ON

CONTROL = OSO

OSO refers to Occupancy Sensing Control. The load will be switched ON when ON-PPU receives 1) control signal from wired LVOS, or 2) wireless command from a grouped ONS/ONB, and reduce lighting to LOW DIM level when programmed delay time elapses.

If the load was switched OFF via an OSB, the ON-PPU will operate in Presentation Mode. The load will remain OFF if motion is detected before the delay time elapse. The ON-PPU will resume OSO control after delay time elapsed.

LVOS	ONS	ONB	ON-PPU-302 Operations	
√	-	-	HIGH DIM	Any LVOS detects occupancy
			LOW DIM	Last active LVOS delay elapses
			Delay reset	Not activated
-	√	-	HIGH DIM	Any ONS detects occupancy
			LOW DIM	ON-PPU delay elapses
			Delay reset	When ONS detects occupancy
-	-	√	HIGH DIM	Any ONB is pressed ON
			LOW DIM	ON-PPU delay elapses
			Load OFF	ONB is pressed OFF
√	√	-	HIGH DIM	Any LVOS/ONS detects occupancy
			LOW DIM	Both LVOS and ON-PPU delays elapse
			Delay reset	When ONS detects occupancy
√	-	√	HIGH DIM	Any LVOS detects occupancy or ONB is pressed ON
			LOW DIM	Last LVOS delay elapses
			Load OFF	ONB is pressed OFF
-	√	√	HIGH DIM	Any ONS detects occupancy or ONB is pressed ON
			LOW DIM	ON-PPU delays elapse
			Load OFF	ONB is pressed OFF
√	√	√	HIGH DIM	Any LVOS/ONS detects occupancy or ONB is pressed ON
			LOW DIM	Both LVOS and ON-PPU delays elapse
			Load OFF	ONB is pressed OFF
√	√	√	HIGH DIM	Any LVOS/ONS detects occupancy or ONB is pressed ON
			LOW DIM	Both LVOS and ON-PPU delays elapse
			Delay reset	When ONS detects occupancy or ONB is pressed ON

CONTROL = OSLATO

OSLATO is a occupancy sensing control scheme that require maintaining LOW DIM lighting for a period of time before shutting off. The load will be switched ON when ON-PPU receives 1) control signal from wired LVOS, or 2) wireless command from a grouped ONS/ONB. After the delay time elapsed, lighting output will be reduced to LOW DIM level for a period of TIME OFF delay before shutoff.

If the load was switched OFF via an OSB, the ON-PPU will operate in Presentation Mode. The load will remain OFF if motion is detected before the delay time elapse. The ON-PPU will resume to OSLATO control after delay time elapsed.

LVOS	ONS	ONB	ON-PPU-302 Operations	
√	-	-	HIGH DIM	Any LVOS detects occupancy
			LOW DIM	Last active LVOS delay elapses
			Load OFF	TIME OFF delay elapsed
-	√	-	Delay reset	Not activated
			HIGH DIM	Any ONS detects occupancy
			LOW DIM	ON-PPU delay elapses
-	-	√	Load OFF	TIME OFF delay elapsed
			Delay reset	When ONS detects occupancy
			HIGH DIM	Any ONB is pressed ON
-	-	√	LOW DIM	ON-PPU delay elapses
			Load OFF	TTIME OFF delay elapsed or ONB is pressed OFF
			Delay reset	When ONB is pressed ON
√	√	-	HIGH DIM	Any LVOS/ONS detects occupancy
			LOW DIM	Both LVOS and ON-PPU delays elapse
			Load OFF	TIME OFF delay elapses
-	√	√	Delay reset	When ONS detects occupancy
			HIGH DIM	Any LVOS detects occupancy or ONB is pressed ON
			LOW DIM	Last LVOS delay elapses
√	-	√	Load OFF	TIME OFF delay elapsed or ONB is pressed OFF
			Delay reset	When ONB is pressed ON
			HIGH DIM	Any ONS detects occupancy or ONB is pressed ON
-	√	√	LOW DIM	ON-PPU delays elapse
			Load OFF	TIME OFF delay elapsed or ONB is pressed OFF
			Delay reset	When ONS detects occupancy or ONB is pressed ON
√	√	√	HIGH DIM	Any LVOS/ONS detects occupancy or ONB is pressed ON
			LOW DIM	Both LVOS and ON-PPU delays elapse
			Load OFF	TIME OFF delay elapsed or ONB is pressed OFF
-	√	√	Delay reset	When ONS detects occupancy or ONB is pressed ON
			HIGH DIM	Any ONS detects occupancy or ONB is pressed ON
			LOW DIM	Both LVOS and ON-PPU delays elapse
√	√	√	Load OFF	TIME OFF delay elapsed or ONB is pressed OFF
			Delay reset	When ONS detects occupancy or ONB is pressed ON
			HIGH DIM	Any ONS detects occupancy or ONB is pressed ON

CONTROL = VSC

VSC refers to Vacancy Sensing Control. This control requires user to turn ON the load by pressing a grouped OSB, and the ON-PPU control the connected lighting as per OSLATO scheme or turn OFF when receiving OFF-command from a grouped OSB.

LVOS	ONS	ONB	ON-PPU-302 Operations	
-	-	√	HIGH DIM	Any ONB is pressed ON
			LOW DIM	ON-PPU delay elapses
			Load OFF	TIME OFF delay elapsed or ONB is pressed OFF
√	-	√	Delay reset	When ONB is pressed ON
			HIGH DIM	Any ONB is pressed ON
			LOW DIM	Both LVOS and ON-PPU delay elapses
-	√	√	Load OFF	TIME OFF delay elapsed or ONB is pressed OFF
			Delay reset	When ONB is pressed ON
			HIGH DIM	Any ONB is pressed ON
√	√	√	LOW DIM	ON-PPU delays elapse
			Load OFF	TIME OFF delay elapsed or ONB is pressed OFF
			Delay reset	When ONS detects occupancy or ONB is pressed ON
-	√	√	HIGH DIM	Any ONB is pressed ON
			LOW DIM	Both LVOS and ON-PPU delays elapse
			Load OFF	TIME OFF delay elapsed or ONB is pressed OFF
√	√	√	Delay reset	When ONS detects occupancy or ONB is pressed ON
			HIGH DIM	Any ONB is pressed ON
			LOW DIM	Both LVOS and ON-PPU delays elapse
-	√	√	Load OFF	TIME OFF delay elapsed or ONB is pressed OFF
			Delay reset	When ONS detects occupancy or ONB is pressed ON
			HIGH DIM	Any ONB is pressed ON