

TRANS

MRB-510 series

Modbus Occupancy & Daylight Sensor

INSTALLATION INSTRUCTIONS

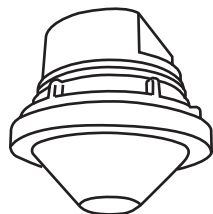

w/Lens A/B/C



w/Lens D

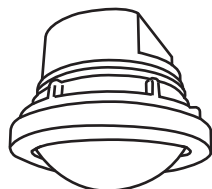

w/Lens F

OVERVIEW

The MRB-510 series member of the TRANS family is an occupancy and daylight sensor designed for Modbus control network. This slave sensor is able to provide occupied/vacant status and ambient light level outputs in Modbus communication protocol for area lighting or HVAC control of building management systems.

This Modbus multi-sensor employs a cutting edge quad element passive infrared (PIR) sensor to provide omni-directional occupancy sensing capability, and an advanced digital ambient light level sensor to provide dynamic ambient light level sensing performance for energy efficient building control. The sensor operation settings can be achieved remotely via Modbus control network.

The innovative interchangeable lens design allows the sensor to provide different occupancy detection coverage without changing or relocating the sensor. Like all sensors in the TRANS family, the MRB-510 series is also available with various mounting options, including ceiling recess, ceiling surface, and junction box mounted. These design innovations offer second to none flexibility for all applications of commercial building control.

INSTALLATION NOTES

1. The sensor is more sensitive to the movements "crossing" the detection zones than "toward" or "away" the sensor unit. To obtain better sensitivity, avoid placing the sensor in line with occupant path, if possible.
2. The closer the movement is to the sensor, the more sensitive the sensor is. The higher the sensor is installed, the larger movement is required to be detected.
3. Ensure to place the sensor at least at 1.5m (5 ft.) away from air supply ducts as rapid air flow may cause false activations.
4. The sensor cannot "see" the movements behind obstacles, such as furniture, shelf, glass or partition. As a general rule, each occupant should be able to clearly view the sensor unit.
5. For open office areas with partition which could block the sensor view to occupant movements, it is best to place the sensors over the intersection of multiple workstations. For large areas of open office or space, place multiple sensors so that there is overlap coverage with each adjacent sensor.

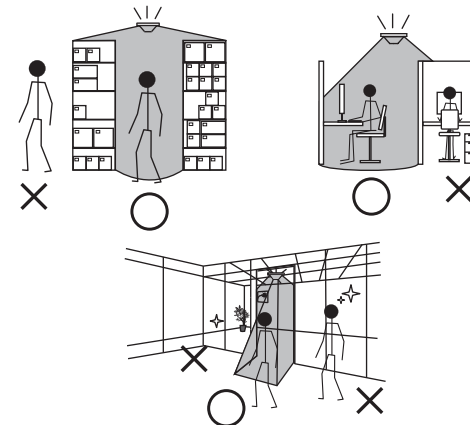

CAUTION

- Do NOT touch the square window of infrared sensor under the lens assembly.
- Do Not Install To and/or Cover a Junction Box Having Class 1, 3 or Power and Lighting Circuits
- Class 2 Device Wiring Only – Do Not Reclassify and Install as Class 1, 3 or Power and Lighting Wiring

PRUDENCE

- Ne PAS toucher la fenêtre carrée de capteur infrarouge sous l'ensemble de l'objectif.
- Ne pas installer ou couvrir une boîte de jonction ayant les classes 1 et 3 ou circuits de puissance et d'éclairage.
- Classe 2 Câblage de périphériques Seulement - Ne PAS reclasser et installer Classe 1, 3 ou alimentation et circuits d'éclairage.

www.irtec.com

P/N: 058-51002-002

Printed in Taiwan

This product may be covered by one or more U.S. patents or patent applications. Please visit www.irtec.com for more information.



IR-TEC

OPERATION

The MRB-510 series is an occupancy and daylight multi-functional sensor designed for Modbus building control network. Powered by low voltage DC, the sensor not only detects the presence of occupant and occupancy status within its detection coverage, but also reports the real-time ambient light level for energy efficient lighting control. All sensor operation and communication settings, including ON/OFF delay times and ambient light level sensing ranges, transmission rate and serial port, can be remotely programmed via Modbus network.

SPECIFICATIONS

Power supply	12~24 VDC±10%
Current drain	Less than 12 mA @24VDC, standby
Output protocol	Modbus, RS-485
Infrared sensor	Omni-directional quad element pyroelectric
Detectable speed	1~10 ft./sec. (0.3~3 m/sec)
Mounting height	Subject to the lens type applied
Detection range	Subject to the lens applied and mounting height
Baud rate	1200/2400/4800/9600/19200/38400/57600/115200
ALS sampling rate	2~60 sec. network programmable
ALS ranges	1~200/2~2,000/20~20,000 lux
ON delay setting	0~5 min. network programmable
OFF delay setting	5 sec.~30 min. network programmable
Op. temperature	-10°C~50°C (-14°F~122°F)
Op. humidity	Max. 95% RH
Dimensions	Ø60 x H37mm (Ø2.36" x H1.45")

WARRANTY

IR-TEC International Ltd. warranties this product to be free of defects in materials or workmanship for a period of five years from date of shipment. There are no obligations or liabilities on the part of IR-TEC International Ltd. for consequential damages arising out or in connection with the use or performance of this product or other indirect damages with respect to loss of property, revenue, or profit, or cost of removal, installation or reinstallation.

SUPPORTED FUNCTION CODES

Item	Function Code	Name	Usage
1	01	Read Coil Status	Read bits
2	03	Read Holding Registers	Read words
3	15	Force Multiple Coils	Write bits
4	16	Force Multiple Registers	Write words

Configuration switch

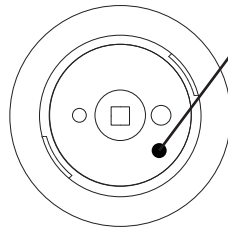

For the sensor to enter the "setting mode", press the button for 5 seconds. The LED indicator will turn on to indicate that the sensor is ready for setting. Complete settings or resume the sensor to factory default via Modbus control interface within 10 minutes.

Termination Resistor

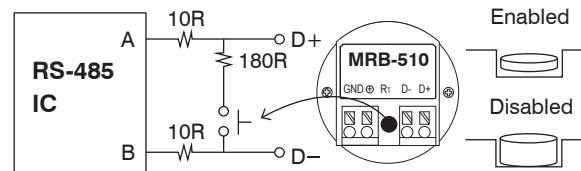

WIRING DIAGRAM

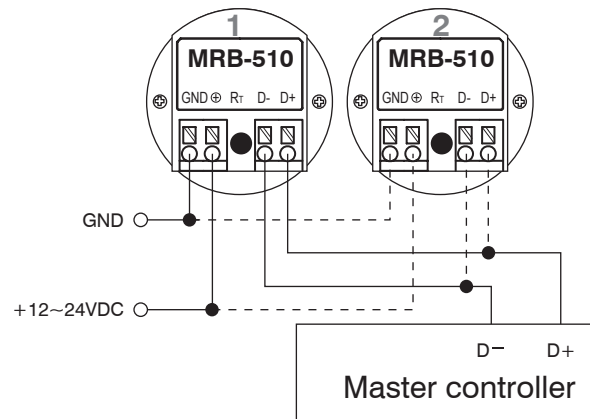

MODBUS REGISTER MAP (16bits)

Reg.	Parameter	R/W	Description	Note																																																
1	Product ID	R	0x3310																																																	
2	Firmware Version	R	0x0001 ~ 0xFFFF																																																	
3	Hardware Version	R	0x0001 ~ 0xFFFF																																																	
4	RS-485 Address	R/W	0x0001 ~ 0x00FA																																																	
5	Serial Port Setting	R/W	<table border="1"> <thead> <tr> <th>LSB</th> <th>Value</th> <th>Rate</th> </tr> </thead> <tbody> <tr><td>0x01</td><td>0x01</td><td>1200 bps</td></tr> <tr><td>0x02</td><td>0x02</td><td>2400 bps</td></tr> <tr><td>0x03</td><td>0x03</td><td>4800 bps</td></tr> <tr><td>0x04</td><td>0x04</td><td>9600 bps</td></tr> <tr><td>0x05</td><td>0x05</td><td>19200 bps</td></tr> <tr><td>0x06</td><td>0x06</td><td>38400 bps</td></tr> <tr><td>0x07</td><td>0x07</td><td>57600 bps</td></tr> <tr><td>0x07</td><td>0x07</td><td>115200 bps</td></tr> </tbody> </table> <table border="1"> <thead> <tr> <th>MSB</th> <th>YY</th> <th>Description</th> </tr> </thead> <tbody> <tr><td>0b000000</td><td>YY</td><td>0b00 No parity</td></tr> <tr><td>0b000001</td><td>YY</td><td>0b01 Even</td></tr> <tr><td>0b000010</td><td>YY</td><td>0b10 Odd</td></tr> <tr><td>0b000011</td><td>YY</td><td>0b11 Ignore</td></tr> <tr><td>X = 0</td><td>X</td><td>One stop bit</td></tr> <tr><td>X = 1</td><td>X</td><td>If YY != 0b00, Ignore If YY = 0b00, Two stop bits</td></tr> </tbody> </table>	LSB	Value	Rate	0x01	0x01	1200 bps	0x02	0x02	2400 bps	0x03	0x03	4800 bps	0x04	0x04	9600 bps	0x05	0x05	19200 bps	0x06	0x06	38400 bps	0x07	0x07	57600 bps	0x07	0x07	115200 bps	MSB	YY	Description	0b000000	YY	0b00 No parity	0b000001	YY	0b01 Even	0b000010	YY	0b10 Odd	0b000011	YY	0b11 Ignore	X = 0	X	One stop bit	X = 1	X	If YY != 0b00, Ignore If YY = 0b00, Two stop bits	
LSB	Value	Rate																																																		
0x01	0x01	1200 bps																																																		
0x02	0x02	2400 bps																																																		
0x03	0x03	4800 bps																																																		
0x04	0x04	9600 bps																																																		
0x05	0x05	19200 bps																																																		
0x06	0x06	38400 bps																																																		
0x07	0x07	57600 bps																																																		
0x07	0x07	115200 bps																																																		
MSB	YY	Description																																																		
0b000000	YY	0b00 No parity																																																		
0b000001	YY	0b01 Even																																																		
0b000010	YY	0b10 Odd																																																		
0b000011	YY	0b11 Ignore																																																		
X = 0	X	One stop bit																																																		
X = 1	X	If YY != 0b00, Ignore If YY = 0b00, Two stop bits																																																		
6	Status	R/W	N/A																																																	
7	System Setting	R/W	<table border="1"> <thead> <tr> <th>LSB</th> <th>Value</th> <th>Description</th> </tr> </thead> <tbody> <tr><td>0b000000</td><td>Y</td><td>Y = 1 Reset all of data to Factory Default</td></tr> <tr><td>0b000001</td><td>Y</td><td>Y = 0 N/A</td></tr> <tr><td>0b000010</td><td>X</td><td>X = 1 Exit Serial Port Setting Mode</td></tr> <tr><td>0b000011</td><td>X</td><td>X = 0 N/A</td></tr> </tbody> </table> <table border="1"> <thead> <tr> <th>MSB</th> <th>Value</th> </tr> </thead> <tbody> <tr><td>0x00</td><td>0x00</td></tr> </tbody> </table>	LSB	Value	Description	0b000000	Y	Y = 1 Reset all of data to Factory Default	0b000001	Y	Y = 0 N/A	0b000010	X	X = 1 Exit Serial Port Setting Mode	0b000011	X	X = 0 N/A	MSB	Value	0x00	0x00	Read 0x0000																													
LSB	Value	Description																																																		
0b000000	Y	Y = 1 Reset all of data to Factory Default																																																		
0b000001	Y	Y = 0 N/A																																																		
0b000010	X	X = 1 Exit Serial Port Setting Mode																																																		
0b000011	X	X = 0 N/A																																																		
MSB	Value																																																			
0x00	0x00																																																			
8	Ambient Light Level	R	0x0001 → 1 Lux 0x07D0 → 2000 Lux																																																	
9	Occupancy	R	<table border="1"> <thead> <tr> <th>LSB</th> <th>Value</th> <th>Description</th> </tr> </thead> <tbody> <tr><td>0b0000000Y</td><td>Y</td><td>Y = 0, Vacant</td></tr> <tr><td>0b0000001Y</td><td>Y</td><td>Y = 1, Occupied</td></tr> </tbody> </table> <table border="1"> <thead> <tr> <th>MSB</th> <th>Value</th> </tr> </thead> <tbody> <tr><td>N/A</td><td>N/A</td></tr> </tbody> </table>	LSB	Value	Description	0b0000000Y	Y	Y = 0, Vacant	0b0000001Y	Y	Y = 1, Occupied	MSB	Value	N/A	N/A																																				
LSB	Value	Description																																																		
0b0000000Y	Y	Y = 0, Vacant																																																		
0b0000001Y	Y	Y = 1, Occupied																																																		
MSB	Value																																																			
N/A	N/A																																																			
10	ON Delay	R/W	0x0000, Disable 0x0001 ~ 0x012C, 1 ~ 300 Sec (max) 0x012D ~ 0xFFFF, Ignore	1bit = 1Second																																																
11	OFF Delay	R/W	0x0000 ~ 0x0004, Ignore 0x0005 ~ 0x0708, 5 ~ 1800 Sec (max) 0x0709 ~ 0xFFFF, Ignore	1bit = 1Second																																																
12	Sampling Rate of Ambient Light	R/W	0x0000 ~ 0x0001, Ignore 0x0002 ~ 0x003C, 2 ~ 60 Sec (max) 0x003D ~ 0xFFFF, Ignore	1bit = 1Second																																																
13	LED Control	R/W	<table border="1"> <thead> <tr> <th>LSB</th> <th>Value</th> <th>Description</th> </tr> </thead> <tbody> <tr><td>0b0000000Y</td><td>Y</td><td>Y = 1, LED Enable</td></tr> <tr><td>0b0000001Y</td><td>Y</td><td>Y = 0, LED Disable</td></tr> </tbody> </table> <table border="1"> <thead> <tr> <th>MSB</th> <th>Value</th> </tr> </thead> <tbody> <tr><td>N/A</td><td>N/A</td></tr> </tbody> </table>	LSB	Value	Description	0b0000000Y	Y	Y = 1, LED Enable	0b0000001Y	Y	Y = 0, LED Disable	MSB	Value	N/A	N/A																																				
LSB	Value	Description																																																		
0b0000000Y	Y	Y = 1, LED Enable																																																		
0b0000001Y	Y	Y = 0, LED Disable																																																		
MSB	Value																																																			
N/A	N/A																																																			