

TRANS

BOM-514 series BOM-515 series

Low Voltage Occupancy Sensor

INSTALLATION INSTRUCTIONS

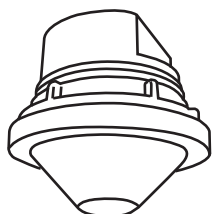

w/Lens A/B/C



w/Lens D

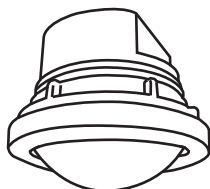

w/Lens F



w/Lens G

*More lens options are available for this sensor.
Please refer to the Lens Datasheet for more details.

⚠ CAUTION & WARNING

- Do NOT touch the square window of infrared sensor under the lens assembly.
- Do Not Install To and/or Cover a Junction Box Having Class 1, 3 or Power and Lighting Circuits.
- Class 2 Device Wiring Only—Do Not Reclassify and Install as Class 1, 3 or Power and Lighting Wiring.
- Suitable wiring range 16-20 AWG solid copper wire only.

OVERVIEW

The BOM-514/515 series member of the TRANS family is a low voltage passive infrared occupancy sensor with dual outputs for versatile applications of occupancy sensing controls and/or building management systems.

This PIR occupancy sensor employs a cutting edge quad element pyroelectric infrared sensor to provide omni-directional sensing capability of occupant's presence and motions. An advanced digital ambient light sensor is integrated to provide smart ambient light level sensing for bi-level or daylight harvesting control.

The first digital output will be active when ambient light level is lower than the threshold level. The second digital output will be active when the sensor detects occupancy and the ambient light level is lower than the threshold level.

Like all sensors in the TRANS family, the BOM-514/515 series is available with various mounting options and interchangeable lenses. This feature provides a second-to-none design and installation flexibility. The sensor is designed to operate in the coldest of environments, down to -40°C/°F.

⚠ AVERTISSEMENT & PRUDENCE

- Ne PAS toucher la fenêtre carrée de capteur infrarouge sous l'ensemble de l'objectif.
- Ne pas installer ou couvrir une boîte de jonction ayant les classes 1 et 3 ou circuits de puissance et d'éclairage.
- Classe 2 Câblage de périphériques Seulement - Ne PAS reclasser et installer Classe 1, 3 ou alimentation et circuits d'éclairage.
- Convient gamme de câblage 16-20 AWG en cuivre massif seulement.

INSTALLATION NOTES

1. The sensor is more sensitive to the movement “crossing” the detection zones than “toward” or “away” the sensor. To obtain better sensitivity, avoid placing the sensor in line with occupant path, if possible.
2. The closer the movement is to the sensor, the more sensitive the sensor is. The higher the sensor is installed, the larger movement is required to be detected.
3. Ensure to place the sensor at least at 1.5m (5 ft.) away from air supply ducts as rapid air flow may cause false activations.
4. The sensor cannot “see” the movements behind obstacles, such as furniture, shelf, glass or partitions. As a general rule, each occupant should be able to clearly view the sensor unit.
5. For open office areas with partition which could block the sensor view to occupant movements, it is best to place the sensors over the intersection of multiple workstations. For large areas of open office or space, place multiple sensors so that there is overlap coverage with each adjacent sensor.

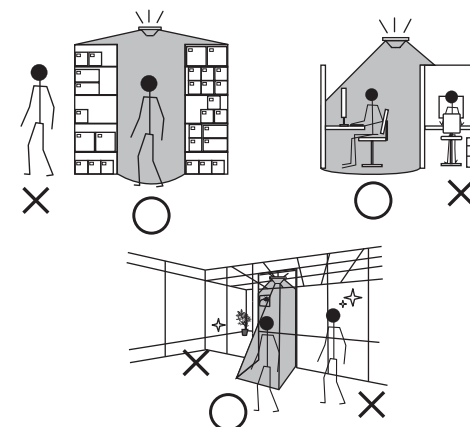

WIRING DIAGRAM

A. Single sensor control

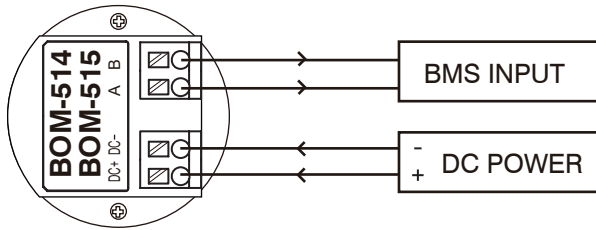

B. Multiple sensors control

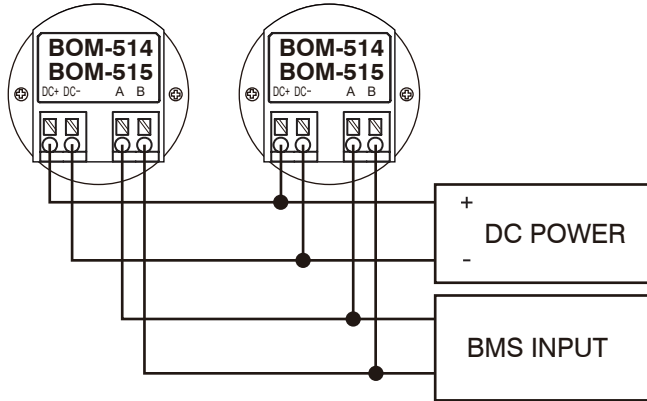

BMS CONTROL APPLICATION

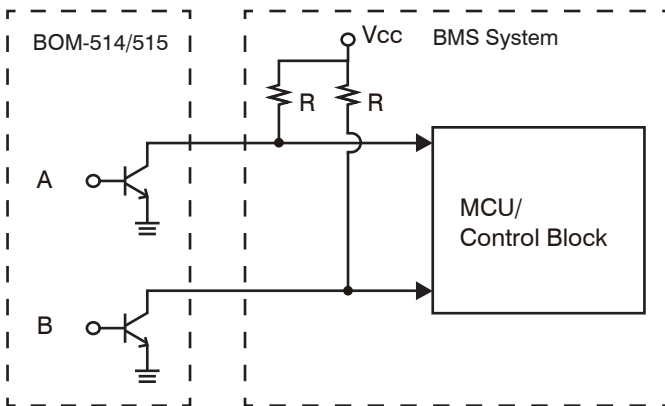

SENSOR SETTINGS

BOM-514Sxx
BOM-515Sxx

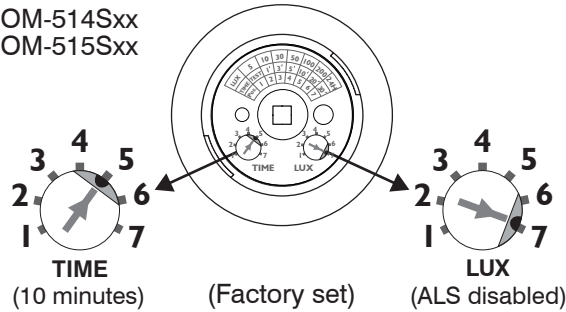

POS.	1	2	3	4	5	6	7
TIME	T	1'	3'	5'	10'	20'	30'
LUX	5	10	30	50	100	200	24H

Factory Set

TIME – Delay Time

The BOM-514Sxx/515Sxx features 7 delay times selectable via Accu-Set digital potentiometer. Select the desired delay time and point the dot mark toward the respective position, sensor output will remain active when it detects occupant's movement until the selected delay time elapsed.

LUX – Ambient Light

The BOM-514Sxx/515Sxx features 7 different ambient light levels selectable via Accu-Set digital potentiometer, which can be set in the same way as TIME setting. The sensor will inhibit its output if ambient light is higher than set level.

TESTING

Sensor Range Test

1. For convenience of range test, you may set the delay time to the shortest.
2. Walk within the desired range* at normal speed from various directions. The load (light, HVAC or others) connected will be switched ON as delay time set whenever sensor detects the presence or movement of occupant.
3. The LED indicator behind the lens assembly will blink to indicate sensor detection as well.

* Depending on the lens type ordered and mounting height, the sensor could have different sensing coverage as instructed on the LENS DATASHEET attached.

SPECIFICATIONS

Power supply	BOM-514: 5~12VDC, BOM-515: 12~24VDC
Current drain	5mA @12VDC, idle
Sensor output A	Day - Open, Night - Low
Sensor output B	Night & Occupied - Low, Others - Open
Infrared sensor	Omni-directional quad element pyroelectric
Detectable speed	0.3~3m/sec (1~10 ft./sec.)
Mounting height	Subject to the lens type applied
Detection range	Subject to the lens applied and height
ALS sensor	Digital, color temperature compensation
Delay time	T/1'/3'/5'/10'/20'/30', T=0 sec. for testing
Ambient level	24Hr/5/10/30/50/100/200 Lux
Op. humidity	Max. 95% RH
Op. temperature	-40°C~55°C (-40°F~131°F)
Dimensions	Ø60 x H37mm (Ø2.36" x H1.45")

*10 lux equals to approximately 1 ft. candle

WARRANTY

IR-TEC International Ltd. warrants this product to be free of defects in materials or workmanship for a period of five years from date of shipment. There are no obligations or liabilities on the part of IR-TEC International Ltd. for consequential damages arising out or in connection with the use or performance of this product or other indirect damages with respect to loss of property, revenue, or profit, or cost of removal, installation or reinstallation.