

BBS-702 series

Low Voltage Wall Switch Sensor

WALLSENZR



OVERVIEW

The BBS-702 series is a member of IR-TEC's WALLSENZR family of low voltage wall switch sensor designed to fit in a standard NEMA wall box. The sensor combines state-of-the-art passive infrared sensing technology with décor aesthetics to provide optimal energy-saving for the applications.

The BBS-702 sensor provides an isolated dry contact together with a unique momentary contact signal to control the load through the connected Power Pack or BMS with Multi-way Manual Control (MMC) available. The MMC is ideal for large area applications where may require multiple wall switch sensors and wall/ceiling mount sensors to cover the whole area, but with manual on/off control available for specific purpose. To meet compliance of specific energy code, such as CA Title 24, the BBS-702 series can be used as vacancy sensor through specific wiring with PPU-300. Under the vacancy sensing control, the connected load will only be switched on by pressing the push-button manually, and switched OFF automatically when delay time of the last motion detected sensor elapses.

The model BBS-702S comes with an ambient light sensor (ALS) to inhibit its output if ambient light level is higher than required. The Accu-Set digital potentiometers make delay time (TIME) and ambient light level (LUX) settings fast, easy and accurate. Isolated dry contact output allows the BBS-702 series to control the load with IR-TEC Power Packs or integrate with BMS/BAS.

FEATURES

- Occupancy and vacancy sensing control available
- Low profile, optimal décor sensor aesthetics
- 180° F. O. V. with coverage exceeds 1,200 sq. ft.
- Specialized lens provides vandalism protection
- Dry contact relay output for versatile control
- Sensor operation LED indicator can be disabled
- Multi-way Manual Control via button operation
- Accu-Set digital potentiometer sensor settings
- Screwless wall plate offers high end appearance

APPLICATIONS

The BBS-702 of IR-TEC's WALLSENZR family can be used for occupancy/vacancy sensing based lighting, or load controls, in a variety of spaces.

Classroom
Conference room
Parking garage
Grand hall
Gymnasium
Industrial assembly

Laboratory
Long corridor
Open office
Self-storage facility
Warehouse
Wide open room



BBS-702 series

Low Voltage Wall Switch Sensor



OPERATION

The BBS-702 series wall switch sensor employs passive infrared (PIR) sensing technology to monitor the occupancy status through an exclusive lens with 180° field of view. An isolated dry contact output will be engaged to turn on the load through the power pack connected. A unique momentary contact signal can be connected with the power pack to provide multi-way manual on/off control.

1. Occupancy Sensor (Auto-ON, Auto-OFF)

Occupancy sensing control switches the light ON automatically when it detects the presence of an occupant. The sensor will switch the light OFF automatically if no occupant activity has been detected before the time delay elapses.

2. Vacancy Sensor (Manual-ON, Auto-OFF)

Vacancy sensing control requires the user to manually press the push-button to turn ON the light. The sensor will switch the light OFF automatically if no occupant activity has been detected before the time delay elapses. The sensor will automatically turn ON the light if it detects occupant activity within 30 seconds after time delay elapsed.

DIMENSIONS

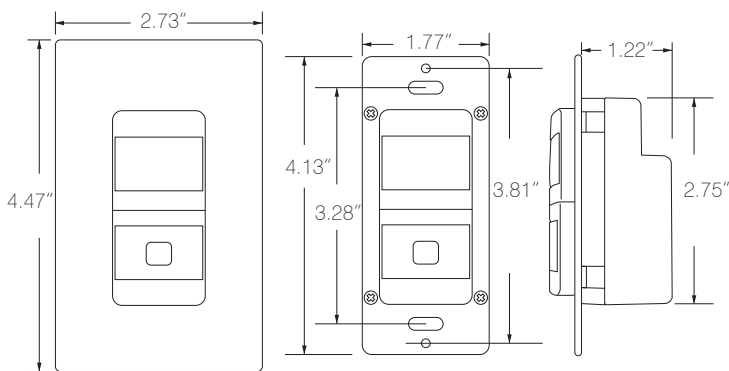

DETECTION COVERAGE

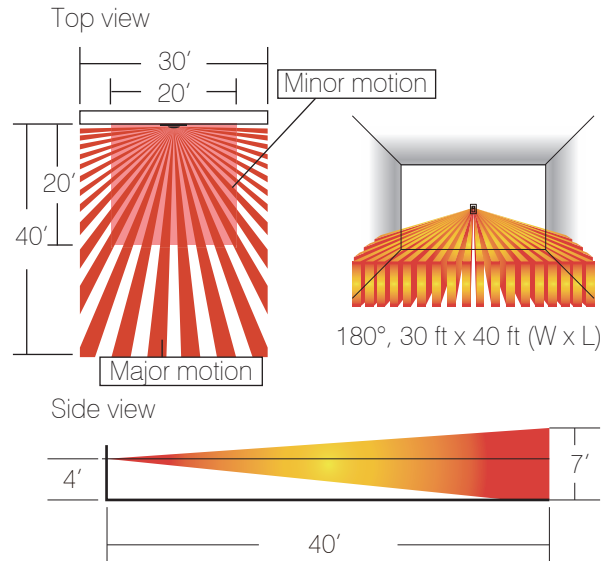

SPECIFICATIONS

Power input	12~24VDC
Current drain	5/20 mA, 24VDC @vacant/occupied
Infrared sensor	Dual element pyroelectric
Control output	Form A dry contact & active low
Contact rating	Max. 2A @30VDC
Detectable speed	1~10 ft./sec. (0.3~3 m/sec)
Mounting height	3 ~ 5 ft. (90~150 cm) above the floor
Detection coverage	Major motion - 30 ft x 40 ft (W x L) @4 ft high Minor motion - 20 ft x 20 ft (W x L) @4 ft high
Ambient light level	7 levels, from dark to 24 Hr.
Delay time setting	T/1'/3'/5'/10'/20'/30', T=10 sec. for testing
Op. humidity	Max. 95% RH, non-condensate
Op. temperature	-40°F ~ 131°F (-40°C ~ 55°C)
Dimensions	4.13"H x 1.77"W x 1.65"D (w/mounting plate)

ORDERING INFORMATION

BBS-702SW – Low Voltage Wall Switch Sensor, 12-24VDC, w/ALS, White

BBS-702SI – Low Voltage Wall Switch Sensor, 12-24VDC, w/ALS, Ivory