

## BED-510 series

### Low Voltage SmartDIM Daylight Sensor



### OVERVIEW

The BED-510 series member of the TRANS family is a 12~24VDC low voltage daylight sensor designed for automatic daylight harvesting in various control modes, including Automatic ON/OFF, SmartDIM, and Virtual Midnight. This sensor is able to continuously measure the ambient light level in the controlled area and provide an isolated dry contact to switch off the unneeded artificial lighting, with 0-10V analog output to maintain constant light level at the area where daylight is available.

This daylight sensor employs a cutting edge digital ambient light sensor (ALS) with an advanced algorithm to provide closed loop, dynamic ambient light level sensing capability. All sensor configurations and setting adjustments can be remotely programmed via a bi-directional IR remote programmer on the floor via intuitive keypad operation. This 2-way remote setting capability does away with the need for ladders, scissor lifts, bucket trucks or any other tools.

Like all TRANS family, the BED-510 series is also available in various mounting options. This feature offers a second-to-none design and installation flexibility for daylight harvesting and control applications in sustainable buildings.

### FEATURES

- Digital data control ambient light sensor
- Human-eye matching spectral response
- Sensor operation LED indicator built-in
- 12~24VDC low voltage power operation
- 2-way IR remote programming capability
- SmartDIM constant lighting level control
- Virtual Midnight for outdoor bi-level control
- Automatic ON/OFF for daylight harvesting
- Available with variety of mounting options

### APPLICATIONS

The BED-510 series daylight sensor can be used in various applications to meet the requirements for daylight harvesting in areas defined as daylight control zones.

- Educational
- Industrial/Retail
- Public buildings
- Commercial

## BED-510 series

### Low Voltage SmartDIM Daylight Sensor

#### Control Modes

The BED-510 series can be programmed to control the connected lighting in one of below modes;

##### Automatic ON/OFF

The relay contact will be engaged when the ambient light level is lower than the ON threshold, and disengaged if the ambient light level is higher than the OFF threshold for a period of time. With the automatic ON/OFF mode, the sensor will provide real time ambient light level in 0-10V output for BMS control.

##### SmartDIM

With SmartDIM control mode, the sensor will constantly measure the ambient light level and dynamically adjust its 0-10V output to achieve constant light level control. If the ambient light level exceeds the Force-OFF threshold for a period of time, the sensor will disengaged its relay output to turn OFF to maximize energy saving.

##### Virtual Midnight

With Virtual Midnight control mode, the sensor will automatically measure the virtual midnight point, and control the output of connected lighting in high and low dim level with respective 0-10V accordingly. The user can program different high and low dim levels to provide desired luminance with the start and end points of low dim period. The time before (T<sub>b</sub>) and time after (T<sub>a</sub>) VM can be separately programmed according to the application and control requirements.

#### Mounting Options

The BED-510 series can be mounted into the ceiling, attached to a fixture or mounted into a junction box to control the connected lighting. Different mounting option is available by combining with specific mounting bracket from the chart below. The bracket will be shipped with the sensor when ordered with the respective code. Mounting option code F and W allow the BED-510SX sensor to be integrated with OEM light fixture for indoor and wet location.

Code	Mounting Option	Mounting Bracket
F	Fixture Integrated	---
W	IP-66 Fixture Integrated	---
E	Fixture External	EMB-500
P	IP-66 Fixture External	PMB-500
S	Ceiling Surface	SMB-500
C	Junction Box	CMB-500
R	Ceiling Recess	RMB-500

#### Wiring Diagram

Basic wiring diagrams are included for general reference. Consult with an IR-TEC team member if a more complex wiring diagram is required.

##### • Standalone Fixture Control

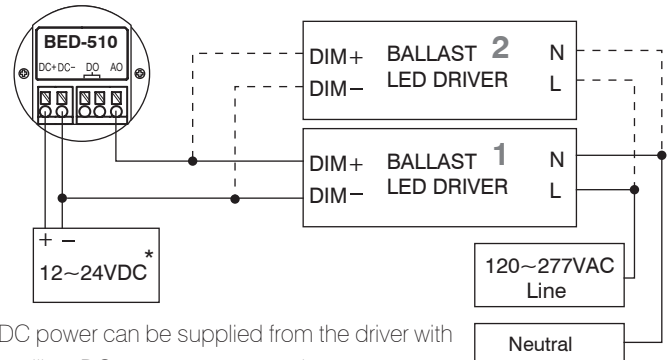

##### • Power Pack Control

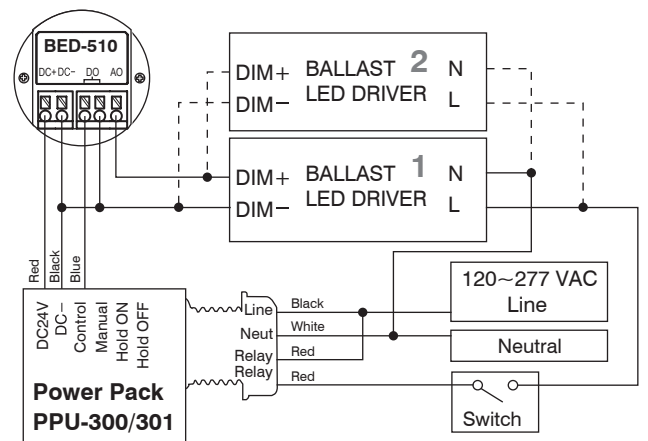

#### SPECIFICATIONS

Power supply	12~24 VDC±5%
Photo sensor	Digital data control ambient light sensor
Current drain	10/20 mA @ 24 VDC, standby/active
Digital output	Isolated dry contact, max. 1A
Dim control	0-10V, max. 25 mA sinking current
T <sub>a</sub> & T <sub>b</sub> for DSVM	0.5-6 Hour programmable
High dim level	SmartDIM or 50-100% StepDIM programmable
Low dim level	0-40% programmable
Sensing range	Approx. 2~2,000 lux (0.2 ~ 200 fc)
Field of view	Approx. 80°
Op. humidity	Max. 95% RH
Op. temperature	-40°C~55°C (-40°F~131°F)
Dimensions	Ø65 x H45mm (Ø2.56" x H1.77")