

## LMD-509 series

### Line Voltage Bi-Level Occupancy Sensor



#### OVERVIEW

The LMD-509 series member of the TRANS family is a line voltage occupancy sensor with 0-10V output for bi-level dimming control. This occupancy sensor employs an advanced High Frequency Doppler (HFD) sensing technology to provide superior sensing performance of minor motion, such as typing, writing, or reading. The HFD technology is operating with high frequency radio waves which are capable of detecting the occupant's presence and movements without requiring unobstructed line-of-sight like a PIR sensor. Thus, the HFD sensor can detect through non-metallic material, such as plastic, glass, plywood or plaster board.

The Accu-Set digitalized potentiometers make the sensor setting easier, faster and more accurate than the conventional analog ones. Four levels of sensitivity and control modes can be selected via DIP switch setting. An exclusive Hybrid Switching technology makes the LMD-509 series perfect to control lighting with exceptionally high inrush current (HIC) during switching, such as multiple LED lightings connected in parallel. The sensor comes with an ambient light sensor (ALS) to inhibit switching on the light if the ambient light level is higher than the threshold set. Like all sensors in the TRANS family, the LMD-509 series is also available in various mounting options.

#### FEATURES

- High Frequency Doppler sensing technology
- 120/240/277 VAC line voltage operation
- Hybrid switching for controlling loads with HIC
- 0-10V output for bi-level dimming control
- Accu-Set potentiometer for quick and easy setting
- 4 levels of HFD sensitivity setting programmable
- 4 control modes selectable via DIP switch setting
- Ambient light sensor to inhibit unneeded lighting
- Available with a variety of mounting options

#### APPLICATION

On/Off Switching Control

0-10V Bi-Level Control

The LMD-509 series occupancy sensor can be used to directly control the connected light, or other loads, by sensing the presence and movements of the occupant without requiring unobstructed line-of-sight. This makes the sensor suitable for applications such as an open office with partitions, a library reading area with cubicles, a restroom with stalls, inside a plastic wall box safety cover, or mounted inside of an enclosed lighting fixture.

NOTE: Do NOT place the sensor behind a metal plate or within an enclosure with metallic wall surrounded.

## LMD-509 series

### Line Voltage Bi-Level Occupancy Sensor

#### OPERATION

The LMD-509 series is a line voltage occupancy sensor featuring hybrid switching contact output to control the power, and a 0-10V output to control the dim level of connected lighting. The sensor will switch on the light when it detects the presence and movement of a moving object (human, or vehicle) within its coverage, and automatically shut off the light after the delay time elapses. Different delay times and ambient light levels can be programmed by respective Accu-Set digital potentiometer. Setting DIP switches #1 and #2 determines the HFD sensitivity, and setting #3 and #4 determines the control mode as below.

#### Control Modes

The sensor can be programmed via DIP switch setting to control the light in specific mode.

Mode	Day <sup>1</sup>	Night <sup>2</sup>	Remarks
OSLATO	Vac: OFF Occ: OFF	Vac: OFF Occ: ON-30%	Dim during Time-Off (TO) delay
OSLA	Vac: OFF Occ: OFF	Vac: 30% Occ: ON	Not applicable for fixture internal integration
OSO	Vac: 30% Occ: ON	Vac: 30% Occ: ON	For spaces require 24-hour lighting
ON/OFF	Vac: OFF Occ: OFF	Vac: OFF Occ: ON	For non-dimmable lighting

**ON/OFF** : ON-OFF Switching

**OSO** : Occupancy Sensing Only

**OSLA** : Occupancy Sensing at Low Ambient

**OSLATO** : Occupancy Sensing at Low Ambient with Time-Off

**Vac** : Vacant    **Occ** : Occupied

<sup>1</sup> While ambient light level is higher than the threshold.

<sup>2</sup> While ambient light level is lower than the threshold.

#### Mounting Options

The LMD-509x series can be mounted into the ceiling or integrated with an OEM lighting fixture in various options. The mounting options are available by combining a specific mounting bracket (if applicable) from the table below. The bracket will be shipped with the sensor when ordered with the respective code.

Code	Mounting Option	Mounting Bracket
F	Fixture Integrated	---
E	Fixture External	EMB-500
S	Ceiling Surface	SMB-500
C	Junction Box	CMB-500
I	Fixture Internal	IMB-500

#### DETECTION PATTERN

Mounting Height	3 m (10 ft)	6 m (20 ft)
Coverage*	180 m <sup>2</sup> (2,000 ft <sup>2</sup> )	100 m <sup>2</sup> (1,200 ft <sup>2</sup> )

\*Sensitivity 100%

Side View

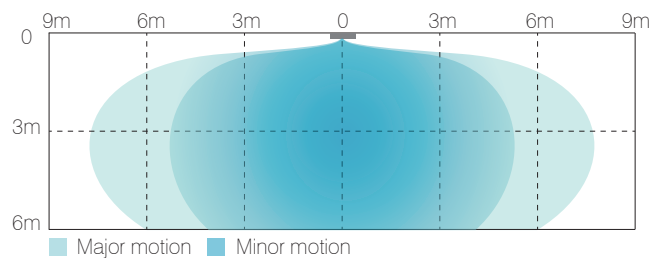

#### Wiring Diagram

Basic wiring diagrams are included as below for reference. Consult with an IR-TEC team member if a more complex control is required.

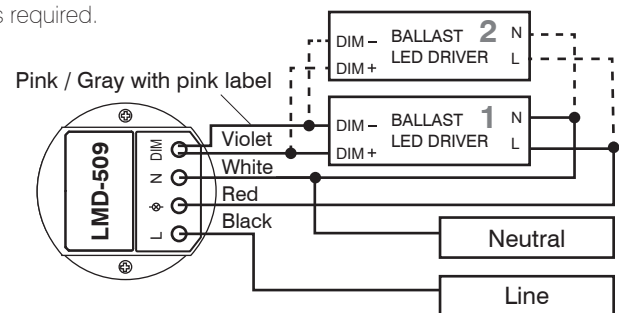

#### SPECIFICATIONS

Power supply	120/240/277VAC, 50/60 Hz		
Maximum Load	120VAC	240VAC	277VAC
-Incandescent/Halogen	800/*500W(VA)	5A	1200/*750W(VA)
-Fluorescent Ballast/CFL	800/*500W(VA)	5A	1200/*750W(VA)
-Ballast Electronic (LED)	540/*500VA	5A	1200/*750VA
HFD sensitivity	25/50/75/100% selectable via DIP switch setting		
Load switching	Zero-cross Hybrid-Switching		
HIC protection	Max. 80A for 16.7msec.		
Dim control	0-10V, non-isolated, max. 25 mA		
Detection range	Up to 180 sq. m. @ 3 m (2,000 sq. ft @ 10 ft)		
Mounting height	2.4 ~ 6 m (8 ~ 20 ft)		
Ambient light level	7 level Accu-Set digital potentiometer		
Delay time setting	T/1'/3'/5'/10'/20'/30', T=10 sec. for testing		
Op. humidity	Max. 95% RH		
Op. temperature	-40°C~70°C (-40°F~158°F)		
Dimensions	Ø60 x H42mm (Ø2.36"x H1.65")		

\*Max load for operating temperature at 55°C~70°C (131°F~158°F)