

MRD-734SZ

SmartDALI Occupancy Sensor



OVERVIEW

The MRD-734SZ is a Zhaga Book 18 Type B compatible DALI occupancy sensor featuring multi-scheme bi-level StepDIM or continuous SmartDIM control for outdoor smart lighting. Through an easy twist and lock connection with standard Zhaga Book 18 receptacle on the luminaire, the sensor can provide smart sensing control as programmed to the integrated luminaire with D4i certified driver.

The sensor employs a digital quad-element passive infrared (PIR) sensor together with the lens applied to detect the motion of occupant/vehicle within the respective sensing coverage. A digital ambient light sensor is built-in to enable daylight harvesting or inhibit unnecessary daytime lighting. The sensor will command DALI driver to provide the programmed output when it detects the presence of an occupant or vehicle, and automatically dim to the low level or shut off the light after the area is vacant for a period of time.

An exclusive two-way handheld remote programmer (SRP-280) allows you to configure sensor control scheme and settings, or download the existing settings of the installed sensor from the ground. IP-66 and IK-08 protections allow the sensor to be used in commercial/industrial applications indoors and outdoors. Multiple lens options offer distinctive coverage for different heights. By connecting the MRD-734SZ to a DALI driver with AUX or bus power integrated*, an energy efficient smart outdoor lighting can be easily available to the market.

*References including Signify SR, OSRAM DEXAL, and other D4i drivers certified by DiiA.

FEATURES

- Omni-directional infrared sensor
- Digital data control ALS for daylight harvesting
- Supports DALI drivers with AUX and bus powers
- Supports 4-pin Zhaga Book 18 edition 2 receptacle
- DALI broadcast command for standalone control
- Multi-level high/low StepDIM or SmartDIM control
- Exceptionally long range of remote programming
- 2-way IR remote programming tool for all settings
- Multiple lens options selectable for different ranges
- IP-66 and IK-08 protections for outdoor applications
- Occupancy sensing status digital output available

APPLICATION

Zhaga based DALI Lighting Control

The MRD-734SZ can be easily applied with outdoor luminaires for parking lots, pedestrian areas, public parks, outdoor display and playgrounds to provide occupancy/vacancy/daylight sensing based standalone control.

DIMENSIONS

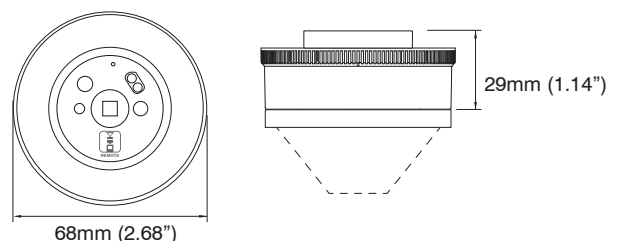

MRD-734SZ

SmartDALI Occupancy Sensor

CONTROL SCHEMES

The sensor can be programmed to control the light in one of the following schemes via remote programmer. For details of specific control mode, please visit www.irtec.com or contact an IR-TEC team member directly.

Mode	Day ¹	Night ²	Remarks
ON/OFF	Vac: OFF Occ: ON/OFF*	Vac: OFF Occ: ON	For non-dimmable lighting *ALS enabled
OSO	Vac: LD Occ: SD/HD	Vac: LD Occ: SD/HD	LD: Low Dim, HD: High Dim SD: SmartDIM
OSLA	Vac: OFF Occ: SD/OFF	Vac: LD Occ: SD/HD	
OSLATO	Vac: OFF Occ: SD/OFF	Vac: LD* -OFF Occ: SD/HD	*Low Dim during Time Off delay
OFF	Vac: OFF Occ: OFF	Vac: OFF Occ: OFF	Light stays off

ON/OFF : ON-OFF Switching

OSO : Occupancy Sensing Only

OSLA : Occupancy Sensing at Low Ambient

OSLATO : Occupancy Sensing at Low Ambient with Time-Off

OFF : Light OFF all the time

Vac : Vacant Occ : Occupied

¹ While ambient light level is higher than the threshold.

² While ambient light level is lower than the threshold.

WIRING DIAGRAM

DALI driver with AUX power / integrated bus power

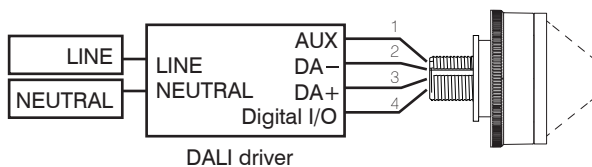

Pin definition

No.	Definition
1	AUX power (+24V)
2*	DALI bus (DA-, GND for AUX power)
3*	DALI bus (DA+)
4	Digital I/O (Occ. status output)

* Follow Zhaga Book 18.

LENS OPTIONS

The MRD-734SZ is available with following lens options which provide different coverage at different mounting heights (H).

Lens	Shape	Mounting Height	Coverage	
A	Standard	Cone	8~15 ft. 2.4~4.5m	2X height
B	Extra wide	Cone	8~10 ft. 2.4~3.0m	6X height
C	High bay	Cone	15~30 ft. 4.5~9.0m	3X height
D	Standard	Round	8~20 ft. 2.4~6.0m	2X height
F	Extra wide	Dome	8~20 ft. 2.4~6.0m	4X height
G	Aisle way	Arch	8~40 ft. 2.4~12.0m	3X height
H	High bay	Dome	30~50 ft. 9.0~15.0m	1X height
L	Long aisle	Arch	8~10 ft. 2.4~3.0 m	6X height

FIXTURE INTEGRATION

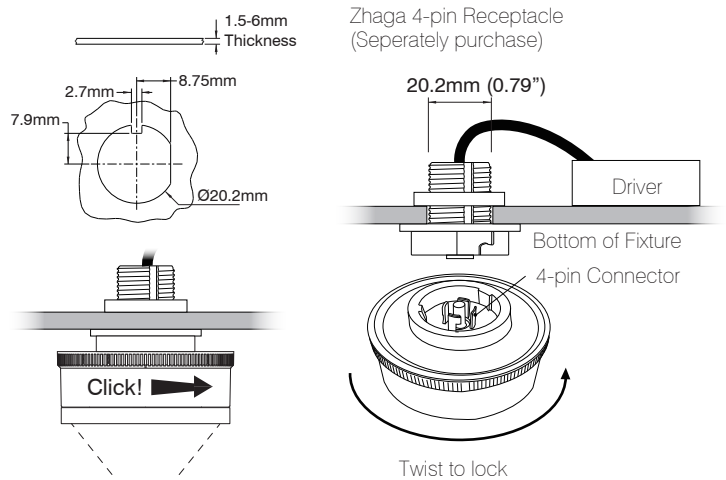

SPECIFICATIONS

Power supply	AUX (+24V) or DALI bus power
Power consumption	< 16 mA with DALI bus
Infrared sensor	Omni-directional pyroelectric
Photo sensor	Digital ambient light sensor
Control protocol	DALI Broadcast
Digital output	16V, 5mA max @pin #4
Detectable speed	0.15 ~ 3 m/sec.
Mounting height	Subject to the lens applied
Detection range	Subject to the lens type and mounting height
Remote range	10 m (33 ft) typical, indoor, no backlight
Op. humidity	Max. 95% RH
Op. temperature	-40°C~70°C (-40°F~158°F)
Dimensions	Ø68 x H29mm (Ø2.68" x H1.14")