

MS-360LP

Low Power PIR Motion Sensor Module



FEATURES

- Excellent motion detection capability
- Wide operation power voltage range
- 360° detection compact dome lens
- Low operation power consumption
- TTL open collector digital output
- Built-in Ambient Light Sensors (ALS)
- Available for ceiling/wall mount device

OVERVIEW

IR-TEC's MS-360LP is a multipurpose, low power Passive Infrared Motion Sensor Module designed for OEM applications. This sensor is able to detect the human body motion within its detection range and output a TTL open collector signal. The sensor employs a dual element pyroelectric infrared sensor and advanced electronics circuit to provide following outstanding features.

APPLICATION

IR-TEC MS-360LP Passive Infrared Motion Sensor can be integrated with the following OEM products.

- Intrusion detectors for wireless alarms
- Wireless lighting control sensors
- HVAC ventilation control sensors
- Battery operated motion activated devices
- Portable devices requires motion sensors

DIMENSIONS

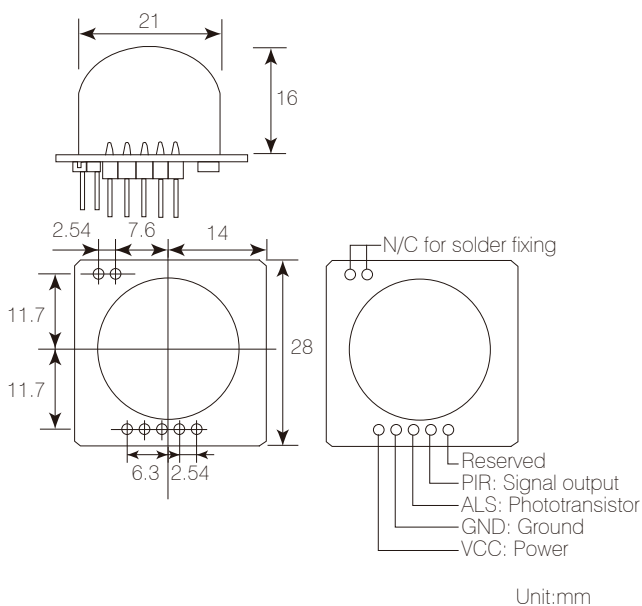

DETECTION PATTERN

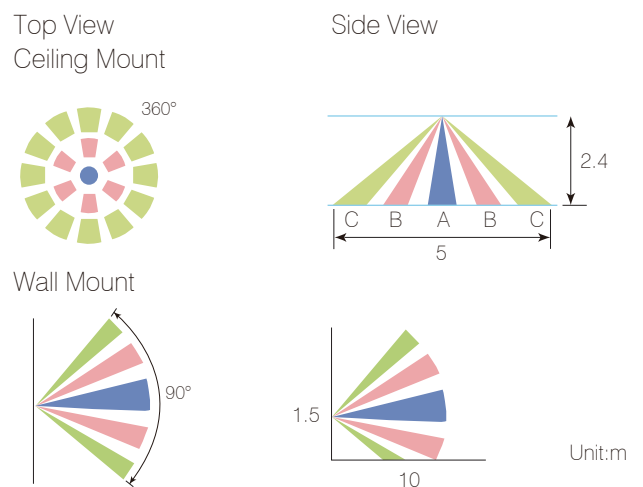

MS-360LP

Low Power PIR Motion Sensor Module

BLOCK DIAGRAM

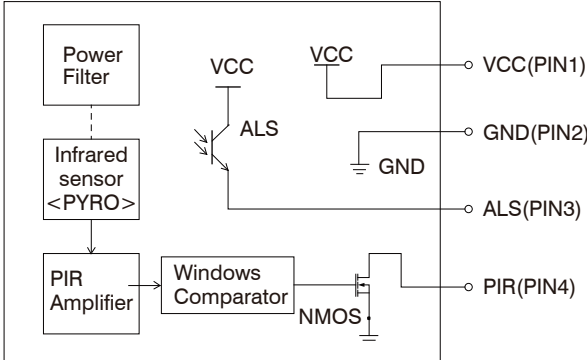

REFERENCE CIRCUIT

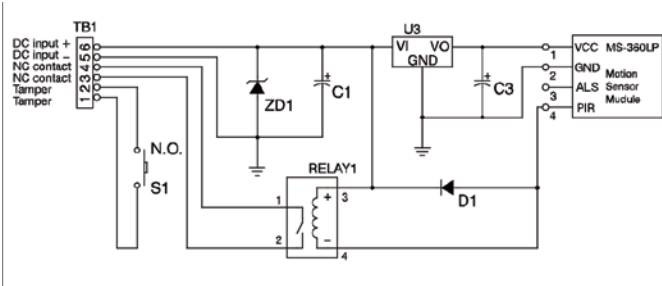

REFERENCE ALS TEST

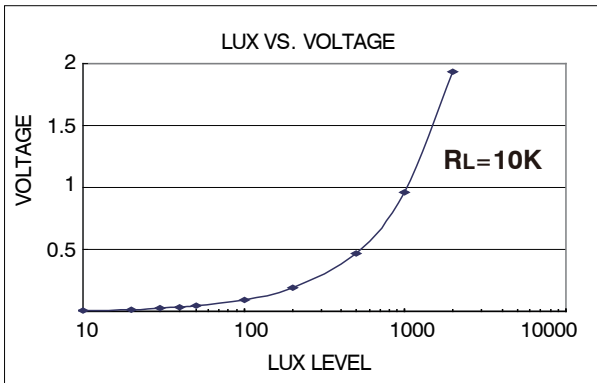
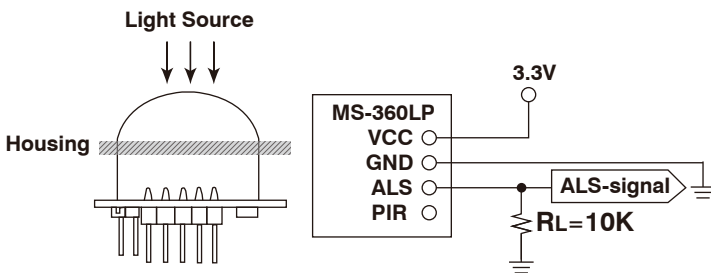

DESIGN NOTICES

If maximum detection coverage is required, please do not block any segment of dome lens. Masking the segments of the lens could block the detection respectively. The sensor is more sensitive to the movements across (crosswise) the sensor than toward (longitudinal) it. Ensure to provide clean and stable power to the module to assure its detection reliability.

SPECIFICATIONS

Power supply	3.6 ± 0.5VDC
Current drain	10uA
Infrared sensor	Dual element, high sensitivity, low noise
Sensor output	Open collector, Active Low
Output period	1 ~ 2.5 sec.
Max. power voltage	5VDC
Max. output voltage	30VDC
Max. output current	100mA (sink)
Light sensor	ALS
ALS dark current	Max. 0.1uA @ 25°C (77°F)
Peak sensitivity wavelength (λp)	630nm
Sensitivity wavelength range (λ)	390 ~ 700nm
Detection range	5m @ 2.4m high (Ceiling: 16 ft. @ 8 ft. high)
	Wall: 10m, 90° wide (10m33 ft.)
Detectable speed	0.15 ~ 3m/sec. (0.5 ~ 10 ft./sec.)
Detection zones	38 zones
I/O connection	2.54 mm (0.1"), 4 x 1 pin connector
Fresnel lens	Ø21mm (0.8") dome Fresnel lens
Mounting height	Ceiling: 6 ~ 10 ft. (1.8 ~ 3m)
	Wall: 1.2 ~ 1.8m (4 ~ 6 ft.)
Warm up time	Approx. 50 sec.
Temperature	-20°C ~ 50°C (-4°F ~ 122°F)
Dimensions	28 x 28 x 16mm (1.1" x 1.1" x 0.63")