

OS-361

Low Voltage Occupancy Sensor



FEATURES

- Cutting edge quad element infrared sensor
- 24VAC/DC low voltage power supply
- Form C dry contact relay output
- Superior RFI and EMI immunity
- Temperature compensation circuitry
- Walk test and sensing status LED indicator
- Easy programmable ON and OFF delays
- High density detection performance
- Recess/surface mount available
- Pigtail wires for easy connection

OVERVIEW

The OS-361 is a 360° ceiling mount low voltage occupancy sensor designed to signal the occupancy status for area lighting, or HVAC control, for energy efficient building management. The sensor is operated by 24V low voltage power supply from an IR-TEC power pack, or building management system, and provides a dry contact signal for control of the connected lighting or HVAC equipment.

A cutting edge quad element pyroelectric infrared sensor and unique Fresnel lens are employed to provide superior occupancy sensing capability. When the sensor detects an occupant's presence, the form C relay contact output will be engaged until the OFF-delay time expires. If the sensor is applied to control the operation of HVAC systems, the ON-delay can be enabled to prohibit short-cycle restarting or unwanted load activation caused by walk-through traffics. Both ON and OFF delays can be easily selected through jumper pin positioning.

APPLICATION

- Light Control
- HVAC Control
- Building Management

The OS-361 can be used to control area lighting, or HVAC, with an IR-TEC power pack or in conjunction with a building management system. Various control modes can be achieved by different wiring connections. Basic wiring diagrams are included. Consult with an IR-TEC team member if a more complex wiring diagram is required.

DETECTION PATTERN

Top View

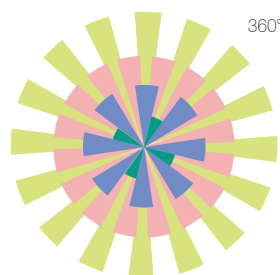

Mounting Height	2.4m	3.0m	3.6m	4.2m
Coverage (dia.)	6m	7.5m	9m	10.5m

Side View

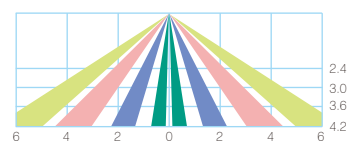

DIMENSIONS

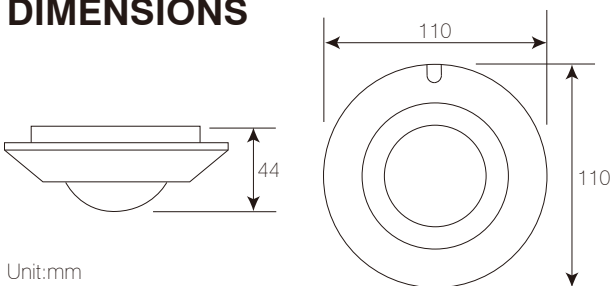

OS-361

Low Voltage Occupancy Sensor

SENSOR OPERATION

The sensor will enter a warm-up period when power is first applied and then operate as described below.

A. Standby mode

The sensor will enter into standby mode after the warm-up period expires. The LED will flash if any jumper is not properly placed on the pin.

B. ON delay mode

If the ON-delay is enabled, the sensor will enter this mode when it first detects the presence of an occupant.

Any further motion detected during the ON-delay mode will NOT reset the timer.

C. 1-minute waiting

When the ON-delay expires, the sensor will enter into the 1-minute waiting period. If no motion is detected within this time period, the sensor will return to standby mode. If motion is detected within this time period, the sensor will engage the relay contact and enter into OFF-delay mode.

D. OFF delay mode

The OFF-delay is the time period that the sensor will hold its relay contact engaged. Every motion detected during this time period will reset the timer. The sensor will return to standby mode if no further motion is detected during this time period and the relay will be disengaged.

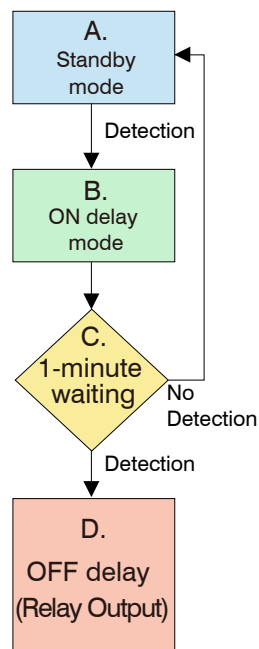

WIRING DIAGRAM

A. Auto-ON/Auto-OFF

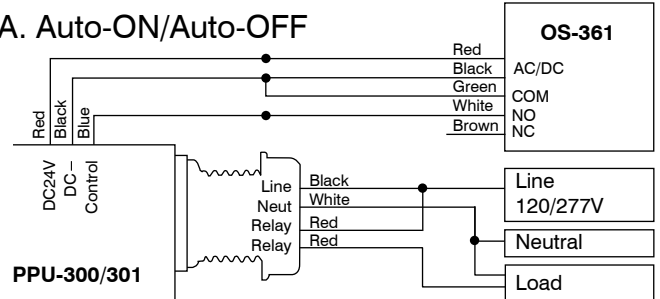

B. Manual-ON/Auto-OFF with PPU-300

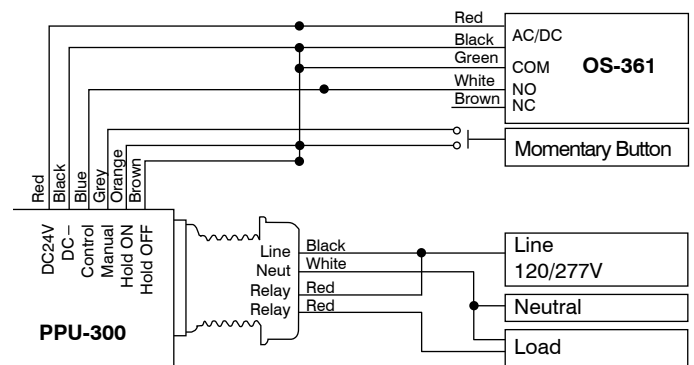

NOTE: Each IR-TEC PPU-300/301 power pack can supply power for up to 6 OS-361 sensors. When more sensors are connected, multiple power packs may be required.

SPECIFICATIONS

Power supply	24 ± 2VAC/DC
Current drain	5/16mA @ 24VAC, vacant/occupied
Infrared sensor	Quad element pyroelectric
Sensor output	Form C, 30VAC/DC, 0.2A max.
Detection range	Mounting height x 2.5
Mounting height	2.4~4.2m (7.9 ft.~13.8 ft.)
Delay time (ON)	0/10"/30"/1'/5'/10' selectable
Delay time (OFF)	10"/1'/5'/10'/20'/30' selectable
RFI immunity	Ave. 20V/m (10~1000MHz)
Humidity	Max. 95% RH
Temperature	-20°C~50°C (-4°F~122°F)
Dimensions	110mm x 44mm (4.3" x 1.7")