

# OS-551

## Low Voltage Occupancy Sensor



### FEATURES

- Cutting edge dual element infrared sensor
- 24VAC/DC low voltage power operation
- Voltage free form C dry contact relay output
- Multi-directional mounting bracket supplied
- Temperature compensated PIR sensitivity
- Superior RFI and EMI immunity protection
- Walk test and sensing status LED indicator
- Easily programmable ON and OFF delays
- Available for wall/corner/ceiling mount

### APPLICATION

- Light Control
- HVAC Control
- Building Management

The OS-551 can be used to control area lighting, or HVAC, with an IR-TEC power pack or in conjunction with a building management system. Various control modes can be achieved by different wiring connections. Basic wiring diagrams are included. Consult with an IR-TEC team member if a more complex wiring diagram is required.

### OVERVIEW

The OS-551 is a low voltage occupancy sensor designed to signal the occupancy status for area lighting, or HVAC control, for energy efficient building management. The sensor is operated by 24VAC/DC power supply from an IR-TEC power pack, or building management system, and provides a dry contact signal for control of the connected lighting or HVAC equipment.

A cutting edge dual element pyroelectric infrared sensor and unique Fresnel lens are employed to provide superior occupancy sensing capability. When the sensor detects an occupant's presence, the relay contact output will be engaged until the OFF-delay time expires. If the sensor is applied to control the operation of HVAC systems, the ON-delay can be enabled to prohibit short-cycle restarting or unwanted load activation. Both ON and OFF delays can be easily set through jumper pin positioning.

The sensor comes with a multi-directional bracket for easy mounting on the ceiling or wall, which also allows horizontal/vertical sensor angle adjustment to achieve optimal coverage.

### DETECTION PATTERN

Top View

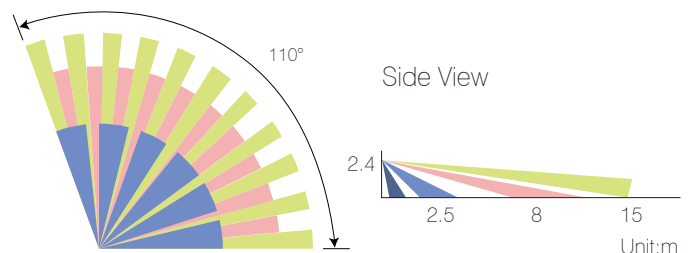

# OS-551

## Low Voltage Occupancy Sensor

### SENSOR OPERATION

The sensor will enter a warm-up period when power is first applied and then operate as described below.

#### A. Standby mode

The sensor will enter into standby mode after the warm-up period expires. The LED will flash if any jumper is not properly placed on the pin.

#### B. ON delay mode

If the ON-delay is enabled, the sensor will enter this mode when it first detects the presence of an occupant.

**Any further motion detected during the ON-delay mode will NOT reset the timer.**

#### C. 1-minute waiting

When the ON-delay expires, the sensor will enter into the 1-minute waiting period. If no motion is detected within this time period, the sensor will return to standby mode. If motion is detected within this time period, the sensor will engage the relay contact and enter into OFF-delay mode.

#### D. OFF delay mode

The OFF-delay is the time period that the sensor will hold its relay contact engaged. Every motion detected during this time period will reset the timer. The sensor will return to standby mode if no further motion is detected during this time period and the relay will be disengaged.

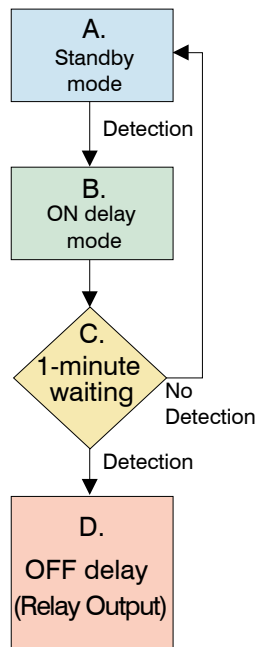

### WIRING DIAGRAM

#### A. Auto-ON/Auto-OFF

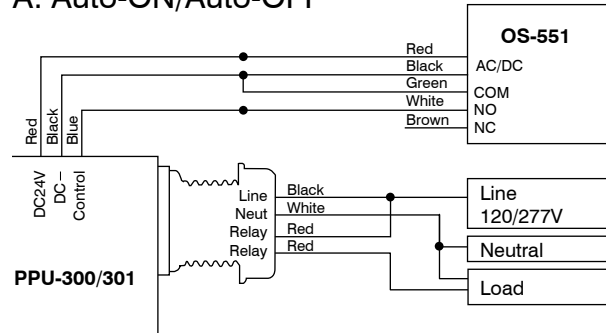

#### B. Manual-ON/Auto-OFF with PPU-300

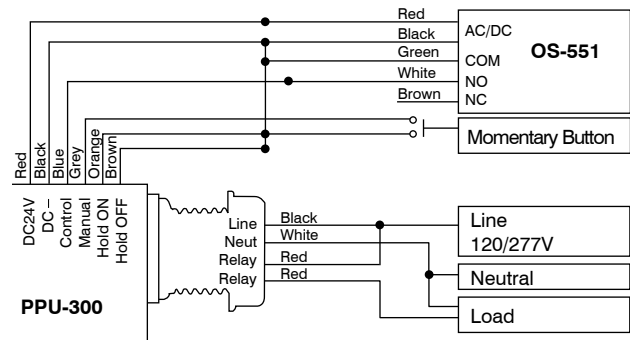

### SPECIFICATIONS

Power supply	24 ± 2 VAC/DC
Current drain	5/18 mA @ 24 VDC, vacant/occupied
Output contact	Form C, Max. 30 VDC, 0.2A
Infrared sensor	Dual element pyroelectric infrared sensor
Detectable speed	0.1 ~ 3 m/sec. (0.33 ~ 10 ft/sec.)
Mounting height	1.8 ~ 3.6 m (6 ~ 12 ft.)
Detection range	110°, 15m @ 25°C (50 ft. @ 77°F)
ON delay setting	0(disabled)/10"/30"/1'/5'/10' selectable
OFF delay setting	10"/1'/5'/10'/20'/30' selectable
Op. humidity	Max. 95% RH
Op. temperature	-20°C ~ 50°C (-4°F ~ 122°F)
Dimensions	112 x 66 x 45 mm (4.4" x 2.6" x 1.8")