

TRANS



BRD-500 series

Low Voltage SmartDIM Occupancy Sensor

INSTALLATION INSTRUCTIONS

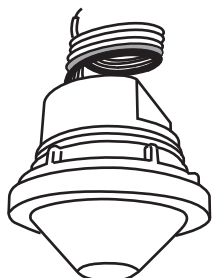

w/Lens A/B/C

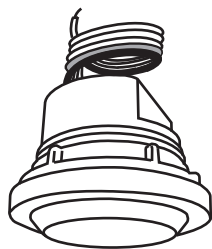

w/Lens D

*More lens options are available for this sensor.
Please refer to the Lens Datasheet for more details.

APPLICABLE REMOTE (order separately)

Model	Description	Remarks
SRP-280	TRANS Remote Programmer	Full functionality
URP-100	User Remote	Manual ON/OFF/DIM TIME/LUX setting

WARNING & CAUTION

- Turn power OFF at circuit breaker before installing Power Pack or Sensors.
- Do NOT touch the square window of infrared sensor under the lens assembly.
- Do Not Install To and/or Cover a Junction Box Having Class 1, 3 or Power and Lighting Circuits.
- Class 2 Device Wiring Only – Do Not Reclassify and Install as Class 1, 3 or Power and Lighting Wiring.

OVERVIEW

The BRD-500 series member of the TRANS family is a two-way IR remote programmable low voltage occupancy sensor with an isolated dry contact for power pack switching and 0-10V output for dimming controls. The sensor is capable of providing fully programmable multi-level high/low dim or SmartDIM control in various modes to achieve top-notch energy efficient lighting control. SmartDIM is a state-of-the-art automatic dimming control technology developed by IR-TEC, which is capable of maintaining the overall ambient light level within the preset range through a smooth, flawless continuous dimming control to the connected lighting.

The sensor will turn on the light connected via an IR-TEC power pack to the high dim or SmartDIM level as programmed when it detects the presence of an occupant or vehicle, and automatically dim the light down to the low level or shut off as programmed after the area is vacated for a period of time. An exclusive two-way handheld remote programmer (SRP-280) allows you to configure sensor setting, or download the existing settings of the installed sensor from the floor.

Like all PIR sensors in the TRANS family, the BRD-500 series is also available with various mounting options and interchangeable lenses. This provides a second-to-none design and complete installation flexibility. The sensor is designed to operate in the coldest of environments, down to -40°C/°F.

AVERTISSEMENT & PRUDENCE

- Coupez l'alimentation au disjoncteur avant d'installer Power Pack ou capteurs.
- Ne PAS toucher la fenêtre carrée de capteur infrarouge sous l'ensemble de l'objectif.
- Ne pas installer ou couvrir une boîte de jonction ayant les classes 1 et 3 ou circuits de puissance et d'éclairage.
- Classe 2 Câblage de périphériques Seulement - Ne PAS reclasser et installer Classe 1, 3 ou alimentation et circuits d'éclairage.

APPLICATION NOTES

1. The sensor is more sensitive to the movements “crossing” the detection zones than “toward” or “away” the sensor unit. To obtain better sensitivity, avoid placing the sensor in line with occupant path, if possible.
2. The closer the movement is to the sensor, the more sensitive the sensor is. The higher the sensor is installed, the larger movement is required to be detected.
3. Ensure to place the sensor at least at 1.5m (5 ft.) away from air supply ducts as rapid air flow may cause false activations.
4. The sensor cannot “see” the movements behind obstacles, such as furniture, shelf, glass or partition. As a general rule, each occupant should be able to clearly view the sensor unit.
5. For open office areas with partition which could block the sensor view to occupant movements, it is best to place the sensor over the intersection of multiple workstations. For large areas of open office or space, place multiple sensors so that there is overlap coverage with each adjacent sensor.

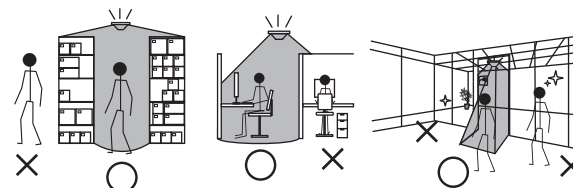

MOUNTING OPTIONS

The sensor can be mounted on the ceiling, or integrated with a lighting fixture in various formats via specific mounting bracket. Please refer to the mounting instruction sheet separately attached for more details.

LENS OPTIONS

Different lenses can be applied to provide specific coverage at different mounting heights. Please refer to the lens datasheet attached for more details.



www.irtec.com

P/N: 058-50019-002

Printed in Taiwan

This product may be covered by one or more U.S. patents or patent applications.
Please visit www.irtec.com for more information.



CONTROL MODE

The BRD-500 series can be programmed by SRP-280 to control the lighting in one of the following modes with various conditions as set. For more details of specific control mode, please visit www.irtec.com or contact an IR-TEC team member directly.

ON/OFF : ON-OFF Switching

OSO : Occupancy Sensing Only

OSLA : Occupancy Sensing at Low Ambient

OSLATO : Occupancy Sensing at Low Ambient with Time-Off

OFF : Light OFF all the time

Mode	Control
ON/OFF	<ol style="list-style-type: none"> While ambient lux is higher than the level set, light stays OFF. While ambient lux is lower than the level set, and occupancy detected, switch the light to HIGH DIM. Turn OFF the light after occupant leave and delay time elapses.
OSO	<ol style="list-style-type: none"> Ambient light sensor disabled. Dim the light to LOW DIM at all time under vacancy. Switch the light to HIGH DIM under occupancy. Dim the light to LOW DIM after occupant leave and delay time elapses.
OSLA	<ol style="list-style-type: none"> While ambient lux is higher than the level set, light stays OFF. While ambient lux is lower than the level set, dim the light to LOW DIM under vacancy. While ambient lux is lower than the level set, and occupancy detected, switch the light to HIGH DIM Dim the light to LOW DIM after occupant leave and delay time elapses.
OSLATO	<ol style="list-style-type: none"> While ambient lux is higher than the level set, light stays OFF. While ambient lux is lower than the level set, and occupancy detected, switch the light to HIGH DIM. Dim the light to LOW DIM after occupant leave and delay time elapses. Turn OFF the lights when TIME OFF delay elapses. When occupancy detected during TIME OFF, switch the light to HIGH DIM.
OFF	<ol style="list-style-type: none"> All lighting controlled by the sensor will remain OFF until another mode is selected.

SENSOR ACKNOWLEDGMENT

Acknowledgement	Sensor LED	Beep	Lighting
Full sensor setting upload completed	-	Long x 1 Short x 2	Flash x 2
Sensor resume to factory default	-	-	Flash x 2
SmartDIM level set completed	-	Short x 2	Flash x 2
Single setting ok	-	Short x 2	-
Occupancy detected	Flash x 1	-	-

SENSOR SETTINGS

The followings are settings and options available with BRD-500 that can be configured through the operation of SRP-280 remote programmer. For more details of remote sensor setting, please refer to the operation instruction of SRP-280.

Settings	Description	Options	Default
CONTROL	The mode that the sensor will control.	ON/OFF, OSO, OSLA, OSLATO, OFF	OSLATO
AMBIENT LUX	The ambient light level that sensor will perform the control.	10/20/40/60/100/200/400 LUX/DISABLED	DISABLED
DELAY	The delay time that sensor is set to turn off or dim the light.	30 sec./1/3/5/10/15/20/30/60 min.	10 min.
TIME OFF	The delay time that sensor will keep the light at low dim level after the OFF delay time elapsed. Only available if OSLATO is selected.	10/30 sec./3/5/10/15/20/30/45/60 min.	10 min.
HIGH DIM	The output level set to control the light during occupancy.	50/55/60/65/70/80/90/100%/SmartDIM	100%
LOW DIM/SmartDIM	The output level set to dim the light when space is vacant for bi-level control. Low dim setting will become SmartDIM bar if SmartDIM control is selected.	0/5/10/15/20/25/30/40%	30%
RAMP UP	The speed of increasing the lighting output to HIGH DIM level.	INSTANT/SOFT/SLOW	INSTANT
FADE DOWN	The speed of decreasing the lighting output to LOW DIM level or off.	INSTANT/SOFT/SLOW	SOFT
LED INDICATOR	Enable/disable the LED indicator of sensor.	ENABLED/DISABLED	ENABLED
SENSITIVITY	The sensitivity of occupancy sensor.	HIGH/NORMAL/LOW	HIGH
MIN. DIM	The lowest dim level applicable on the sensor.	12%/15%/DISABLED	DISABLED
DAY O'RIDE	Enable/disable daylight override control. Sensor will shut off the light when ambient lux exceeds the override level set below. Only available if AMBIENT LUX is enabled.	ENABLED/DISABLED	DISABLED
O'RIDE LEVEL	The ambient lux level to enable daylight override. Only available if DAY O'RIDE is enabled.	HIGH(~1.8X)/NORMAL(~1.5X)/LOW(~1.3X)	NORMAL

WIRING DIAGRAM

SmartDIM control with power pack

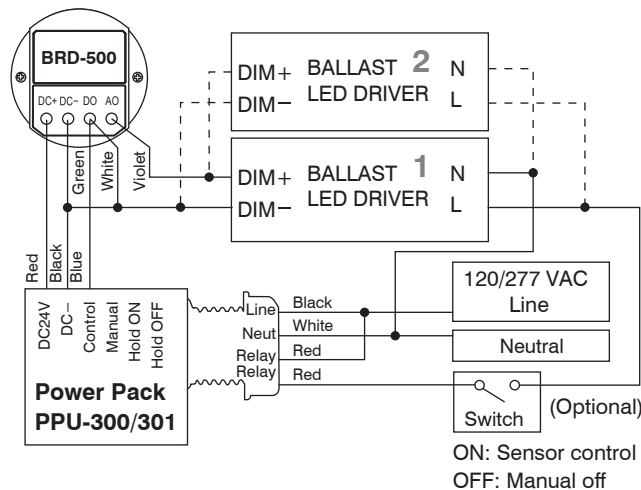

NOTE: Each IR-TEC PPU-300/301 power pack can supply power for up to 6 BRD-500 sensors. When more sensors are connected, multiple power packs may be required.

SPECIFICATIONS

Power voltage	12-24 VDC
Current Drain	11/23 mA @ 24 VDC, vacant/occupied
Infrared sensor	Omni-directional pyroelectric
Photo sensor	Digital ambient light sensor
Sensor output	Isolated dry contact, 48 VDC, 1A max.
Dim control	0-10V, ±5%, max. 25 mA sinking current
Detectable speed	0.3 ~ 3 m/sec. (1~10 ft./sec.)
Mounting height	Subject to the lens type applied
Detection range	Subject to the lens applied and height
Remote range	10 m (33 ft) indoor
Op. humidity	Max. 95% RH
Op. temperature	-40°C~55°C (-40°F~131°F)
Dimensions	Ø60 x H37mm (Ø2.36"x H1.45")