

TRANS

BDS-600SS series

Low Voltage Dual-Tech Occupancy Sensor

INSTALLATION INSTRUCTIONS

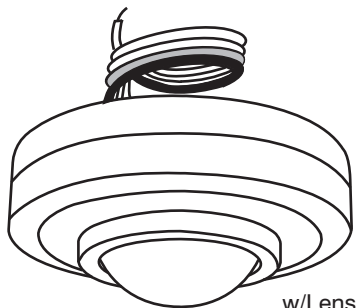

w/Lens F

Indoor dry location use only

Utilisation a L'interieur Uniquement

*More lens options are available for this sensor.

Please refer to the Lens Datasheet for more details.

⚠ WARNING & CAUTION

- Turn power OFF at circuit breaker before installing Power Pack or Sensors.
- Do Not Install To and/or Cover a Junction Box Having Class 1, 3 or Power and Lighting Circuits.
- Class 2 Device Wiring Only – Do Not Reclassify and Install as Class 1, 3 or Power and Lighting Wiring.
- Install the sensor at least 1ft. away from any occupant.

⚠ AVERTISSEMENT & PRUDENCE

- Coupez l'alimentation au disjoncteur avant d'installer Power Pack ou capteurs.
- Ne pas installer ou couvrir une boîte de jonction ayant les classes 1 et 3 ou circuits de puissance et d'éclairage.
- Classe 2 Câblage de périphériques Seulement - Ne PAS reclasser et installer Classe 1, 3 ou alimentation et circuits d'éclairage.

OVERVIEW

The BDS-600SS series member of the TRANS family is a low voltage dual-tech occupancy sensor designed for energy efficient lighting control. This sensor combines digital Passive Infrared (PIR) and state-of-the-art High Frequency Doppler (HFD) sensing technologies into an aesthetically pleasing, installer friendly, low profile housing to provide second-to-none occupancy sensing performance for today's sustainable buildings.

The sensor provides an isolated dry contact output for load switching through a Power Pack or a Building Management System. In addition, the sensor employs a digital ambient light sensor to inhibit the output when ambient light level is higher than the threshold set. The digital Accu-Set potentiometers make delay time and lux level settings fast, easy and accurate. Numerous types of lens can be applied to offer different PIR sensing ranges required for all applications. The sensitivity of HFD sensor can be adjusted if necessary.

The sensor comes with color coded wires for direct wiring connection. A unique mounting bracket with snap-on clip makes the sensor installation an easy job. With the BDS-600SS series sensor, you can easily deliver an occupancy sensing based lighting/HVAC control to all applications.

INSTALLATION NOTES

1. PIR sensor is more sensitive to the movements "crossing" the detection zones than "toward" or "away" the sensor unit. Avoid placing the sensor in line with the path of occupant, if possible.
2. PIR sensor cannot "see" the movements behind obstacles, such as furniture, shelf, glass or partitions. As a general rule, ensure to place the sensor at where the occupant could have clear view of the sensor.
3. HFD sensor may penetrate through certain types of non-metallic partition material (glass, plaster, plywood...etc) and thus detects the movements outside of partition. Adjusting the HFD sensitivity may be necessary to obtain optimum detection.
4. Place the sensor at least at 1.5m (5 ft.) away from air supply duct and fluorescent lighting to avoid false activating.
5. For open office areas with partition which could block the sensor view to occupant movements, it is recommended to place the sensors over the intersection of multiple workstations. For large areas of open office or space, place multiple sensors so that there is overlap coverage with each adjacent sensor.
6. The BDS-600SS can be mounted on the ceiling, via a mounting bracket, with or without a junction box.

SPECIFICATIONS

Power supply	12~24 VDC±5%
Current drain	20/45 mA@24VDC, vacant/occupied
Motion sensor	Digital PIR & High Frequency Doppler
Infrared sensor	Digital omni-directional pyroelectric
HFD frequency	10.525GHz
HFD output power	Max. 12dBm EIRP
Light sensor	Digital, color temperature compensation
Control output	Form A relay, NO, dry contact
Contact rating	30VDC, 2.0A max. isolated
Detectable speed	0.15~3 m/sec (0.5~10 ft./sec.)
Mounting height	2.4~6 m (8~20 ft.)
Detection range	Subject to the lens applied and height
Delay time	T/1/3/5/10/20/30 min. T:10 sec. for test
Ambient light level	5/10/30/50/100/200/24H lux & disabled
HFD sensitivity	40~100% adjustable
Op. humidity	Max. 95% RH
Op. temperature	-10°C~50°C (14°F~122°F)
Dimensions	Ø110 x H25mm (Ø4.33"x H1.0")

Federal Communication Commission Interference Statement

This device complies with Part 15 of the FCC Rules. Operation is subject to the following two conditions: (1) This device may not cause harmful interference, and (2) this device must accept any interference received, including interference that may cause undesired operation.

This equipment has been tested and found to comply with the limits for a Class B digital device, pursuant to Part 15 of the FCC Rules. These limits are designed to provide reasonable protection against harmful interference in a residential installation. This equipment generates, uses and can radiate radio frequency energy and, if not installed and used in accordance with the instructions, may cause harmful interference to radio communications. However, there is no guarantee that interference will not occur in a particular installation. If this equipment does cause harmful interference to radio or television reception, which can be determined by turning the equipment off and on, the user is encouraged to try to correct the interference by one of the following measures:

FCC ID: NRISB56X001

- Reorient or relocate the receiving antenna.
- Increase the separation between the equipment and receiver.
- Connect the equipment into an outlet on a circuit different from that to which the receiver is connected.
- Consult the dealer or an experienced radio/TV technician for help.

FCC Caution: Any changes or modifications not expressly approved by the party responsible for compliance could void the user's authority to operate this equipment.

This transmitter must not be co-located or operating in conjunction with any other antenna or transmitter.

Radiation Exposure Statement:

This equipment complies with FCC radiation exposure limits set forth for an uncontrolled environment. This equipment should be installed and operated with minimum distance 20cm between the radiator & your body.



www.irtec.com P/N: 058-60006-005 Printed in Taiwan

This product may be covered by one or more U.S. patents or patent applications. Please visit www.irtec.com for more information.



SENSOR OPERATION

With 12-24 VDC power supplied, the BDS-600SS will activate its output when PIR sensor detects the presence of occupant. The delay time starts and HFD sensor will start operating to detect minor motion within the range. The output will be continuously engaged if PIR or HFD detects the motion of occupant. The sensor output can be set to inhibit when ambient light level is higher than the threshold. Sensor will disengage the output if no motion is detected before the delay time elapses.

WIRING DIAGRAM

Various sensing controls can be achieved by different wiring connection with IR-TEC Power Pack and other devices. Following diagrams are just typical controls for reference. For the wiring diagrams of more complex controls, please contact an IR-TEC team member directly.

A. Building Management System control

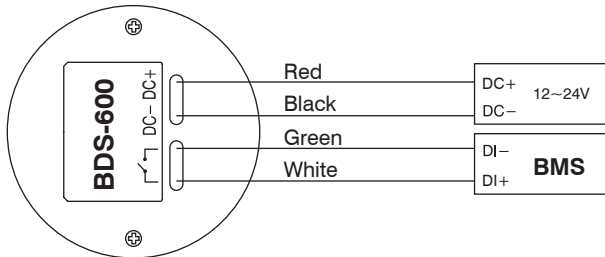

B. Power Pack control

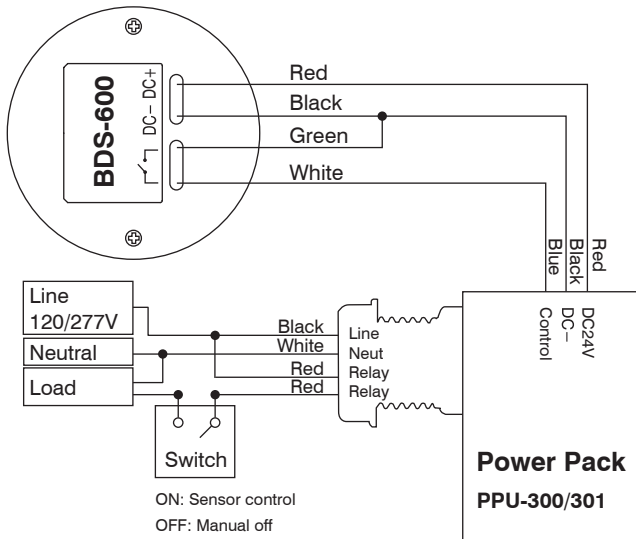

NOTE: Each IR-TEC PPU-300/301 power pack can supply power for up to 3 BDS-600SS sensors. When more sensors are connected, multiple power packs may be required.

SENSOR MOUNTING

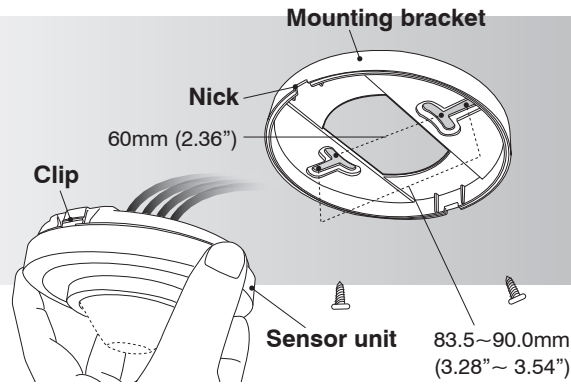

1. Mount the bracket with screws at the selected position.
2. Connect the wires from IR-TEC Power Pack and other control devices (if applicable) to the correct terminal according to the wiring diagram of the desired control.
3. Align the clip of sensor to the nick on the bracket, and snap-on the sensor with the bracket.

NOTE: To release the sensor from the bracket, use a common blade screwdriver to push into either slot.

LENS OPTIONS

Different lenses can be applied to provide specific coverage at different mounting heights. Please refer to the lens datasheet attached for more details.

RANGE TEST

It is recommended to conduct a walk test to verify optimum coverage after the sensor is installed. To verify the sensor range, restore the lens and apply the power to the sensor. The LED will flash whenever sensor detects the motion, blue is PIR and green is HFD. If the space has multiple entrances, repeat the test in all possible paths.

NOTE: The sensor range is primarily determined by the PIR lens type applied and the mounting height.

HFD Range

The coverage of HFD sensor varies with the space pattern and mounting height. Following table highlights typical ranges in an open space at different mounting heights with sensitivity set at maximum.

Height	2.4 m (8 ft)	3.0 m (10 ft)	6.0 m (20 ft)
Range in dia.	12 m (40 ft)	10 m (33 ft)	8 m (27 ft)

SENSOR SETTINGS

The sensor settings can be easily changed via 3 potentiometers around the center.

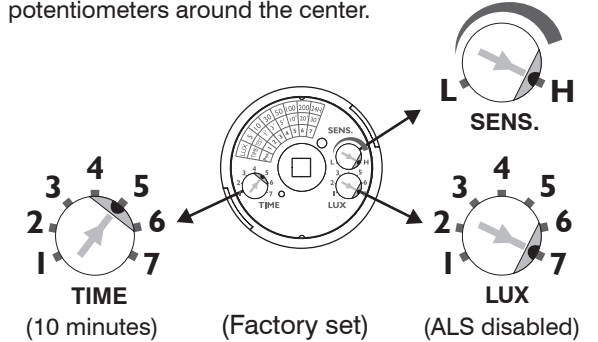

POS.	1	2	3	4	5	6	7
TIME	T**	1'	3'	5'	10'	20'	30'
LUX*	5	10	30	50	100	200	24H

*10 lux equals to approximately 1 ft. candle **Factory Set**
 **T=10 seconds shorten delay for testing convenience. The sensor will automatically resume to the factory default delay setting after 10 minutes, if the potentiometer has not been adjusted to other position.

TIME – Delay Time

7 different delay times can be selected via pointing the Accu-Set digital potentiometer toward the respective position. The sensor output will remain engaged if PIR or HFD sensor detects the occupancy until the selected delay time elapses.

LUX – Ambient Light

7 different ambient light levels can be selected via pointing the Accu-Set digital potentiometer toward the respective position. The sensor will inhibit its output if the ambient light level is higher than the threshold set.

SENS – HFD Sensitivity

The HFD sensitivity can be reduced from 100% to approximately 40% by adjusting the potentiometer in counter-clockwise.

WARRANTY

IR-TEC International Ltd. warranties this product to be free of defects in materials or workmanship for a period of five years from date of shipment. There are no obligations or liabilities on the part of IR-TEC International Ltd. for consequential damages arising out or in connection with the use or performance of this product or other indirect damages with respect to loss of property, revenue, profit, or cost of removal, installation or reinstallation.